

Logic Panel, Graphic Panel

SmartStudio V2.0

USER MANUAL



SmartStudio V2.0

Preface





Thank you very much for selecting Autonics products.

This user manual contains information about the product and its proper use, and should be kept in a place where it will be easy to access.

SmartStudio User Manual Guide

- Please familiarize yourself with the information in this manual before using the product.
- This manual provides detailed information on the product's features. It does not offer any guarantee concerning matters beyond the scope of this manual.
- This manual may not be edited or reproduced in either part or whole without permission.
- This programming manual is not provided as part of the product package. Please visit our home-page (www.autonics.com) to download a copy.
- The manual's content may vary depending on changes to the product's software and other unforeseen developments within Autonics, and is subject to change without prior notice. Upgrade notice is provided through our homepage.
- We contrived to describe this manual more easily and correctly. However, if there are any corrections or questions, please notify us these on our homepage.

SmartStudio User Manual Symbols

Symbol	Description
 Note	Supplementary information for a particular feature.
 Warning	Failure to follow instructions can result in serious injury or death.
 Caution	Failure to follow instructions can lead to a minor injury or product damage.
 Ex.	An example of the concerned feature's use.
※1	Annotation mark.

※ The specifications and dimensions of this manual are subject to change without any notice.

Table of Contents

Preface	iii
SmartStudio User Manual Guide	iv
SmartStudio User Manual Symbols	v
Table of Contents	vi
1 Overview	9
1.1 Feature of SmartStudio	9
1.2 System requirements	10
1.3 Installation of SmartStudio	10
1.4 SmartStudio Screen Layout	13
1.4.1 Menu	14
1.4.2 Toolbar	22
1.4.3 Work space	23
1.4.4 Message box	23
1.4.5 Status bar	23
2 Project	25
2.1 New project	25
2.2 Open project	26
2.3 Open from PLC	26
2.4 Save project	27
2.5 Save Project As	28
2.6 Close project	28
2.7 Load project	29
2.7.1 New project	29
2.7.2 Saved project	30
2.7.3 Open from PLC	31
2.7.4 Change PLC Type	31
2.8 Print Project	32
2.9 Preview	32
2.10 Printer settings	38
2.11 Exit	38
3 Edit	39
3.1 Undo	39
3.2 Cut	40
3.3 Copy	41
3.4 Paste	41
3.5 Insert mode/Edit mode	41
3.6 Insert line	42
3.7 Delete line	43
3.8 Increase ladder column	44
3.9 Decrease ladder column	45

3.10	Edit rung comment.....	46
3.11	Find.....	46
3.12	Replace	48
3.13	Find step	49
4	Tool.....	51
4.1	Ladder tool	51
4.1.1	Arrow	51
4.1.2	Delete	52
4.1.3	Vertical line.....	53
4.1.4	Horizontal line.....	54
4.1.5	Input instruction	55
4.1.6	Output instruction	57
4.1.7	Application instructions	59
4.1.8	NOT instruction	60
4.1.9	Register user defined function	61
4.1.10	User defined function	62
4.2	Program checking	64
4.2.1	Program optimization	64
4.2.2	Program checking and options.....	67
5	View.....	69
5.1	Ladder/Mnemonic	69
5.2	Device name	69
5.3	Variable name	69
5.4	Device name & Variable name.....	70
5.5	Device name & Comment.....	70
5.6	Used devices.....	71
5.7	Decimal/Hexadecimal view	74
5.8	Signed/Unsigned view.....	74
5.9	UW (GP device)/Device (LP device) view.....	75
5.10	Zoom in/out.....	76
5.11	Font settings	77
5.12	Color settings	77
5.13	Toolbar	78
5.14	Workspace	78
5.15	Message box.....	78
6	Online.....	79
6.1	Connecting.....	79
6.2	Disconnecting.....	79
6.3	Download	80
6.4	Upload	81
6.5	Change mode.....	82
6.6	Start monitoring/Stop monitoring	83
6.7	Read information	84
6.8	Change password.....	85

6.9	Verify	86
6.10	Change present value	87
6.11	System device	88
6.12	Delete.....	89
	6.12.1 Data	89
	6.12.2 Program/Parameter.....	89
6.13	Firmware download.....	90
6.14	Communication options.....	92
	6.14.1 Serial communication	93
	6.14.2 Ethernet communication.....	94
	6.14.3 USB communication	95
7	Debug	97
7.1	Run.....	97
7.2	Stop run.....	97
7.3	Trace.....	97
7.4	Insert/Remove break point.....	97
7.5	Stop Debugging	98
7.6	Debug-step	98
7.7	Debug-line.....	98
7.8	Debug-Scan	99
7.9	Debug-1 scan.....	99
7.10	Step in	100
7.11	Step out.....	101
7.12	Debug-bit.....	102
7.13	Debug-word	103
7.14	Forced I/O settings.....	104
8	Window	105
8.1	Cascade.....	105
8.2	Horizontal tile	105
8.3	Vertical tile.....	106
8.4	Arrange icon.....	106
8.5	External program connection.....	107
9	Workspace	109
9.1	Ladder/Mnemonic program.....	109
9.2	Variable/Comment.....	110
9.3	Monitoring.....	111
9.4	Parameter.....	112
	9.4.1 Common.....	112
	9.4.2 Extension.....	114
	9.4.3 Motion.....	125

1 Overview

1.1 Feature of SmartStudio

SmartStudio is the exclusive software to write program and debug for LP series. Features and advantages of SmartStudio are as below.

- Supports multi project
You can open up to 5 projects at the same time and write or edit programs.
- Convenient program edit
 - Enables to edit by cell unit
 - Enables to edit with multi window
 - Supports several view functions such as viewing device name, variable name, or device name & comment, etc to edit program easily.
 - You can edit ladder program and mnemonic program at the same time.
- Several monitor function
Supports several monitor function such as monitoring variable, device, system, or time chart, etc.
- Convenient user interface
Easy adaptation for SmartStudio by same basic function of Microsoft window.
- Various message window
Supports various message window for edit or check program easily.
- Real time switching ladder and mnemonic program
Switching ladder or mnemonic program in real time and it is available to write or edit at two editors simultaneously.

1.2 System requirements

Operating system: Windows 98/NT/XP

Item	Minimum specifications	Recommended specification
CPU	Pentium 4 or above	Pentium Dual Core
Memory	512 MB	1GB
Hard disk	1 GB (Free space)	5GB (Free space)
Resolution	1024 × 768	1280 × 1024

Communication port: RS232, Serial, USB, Ethernet

1.3 Installation of SmartStudio

1st For installing SmartStudio, visit our homepage(www.autonics.com) and download SmartStudio program.

2nd Double-click installation setup file, and installation is start as a following figure. Click 'Next' to continue installation, or 'Cancle' to discontinue installation.

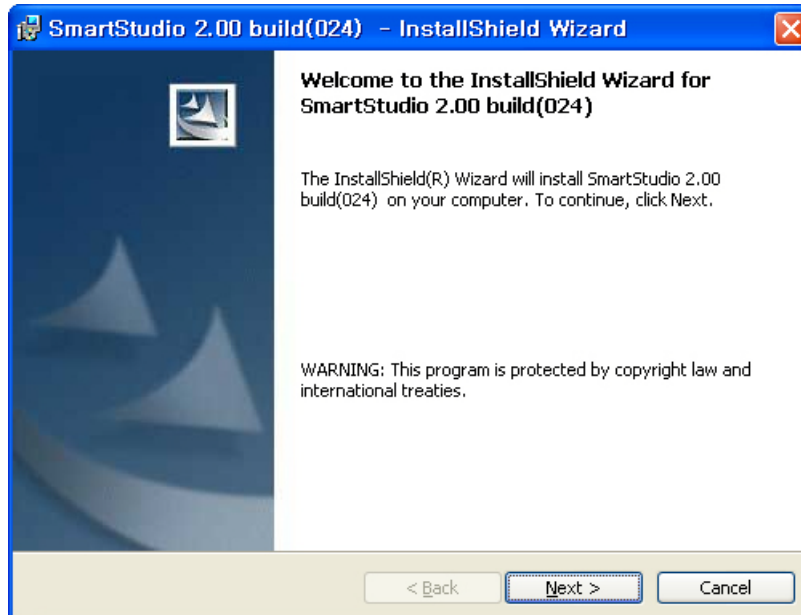

3rd Designate installation location, and click 'Next'. To change the installation location, click 'Change' and select the desired folder and click 'OK'.

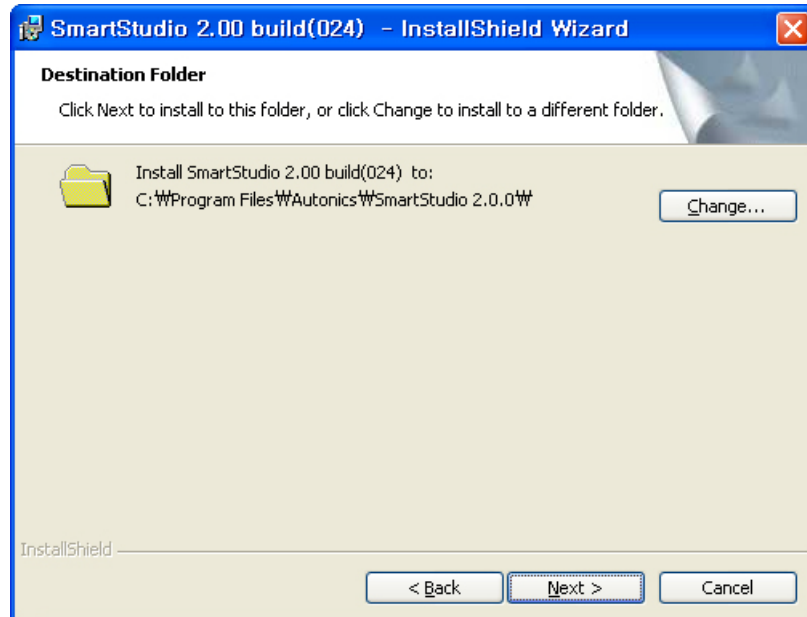

4th Check current settings for installation such as setup type, destination folder, and user information. To change the settings, click 'Back'. To start installation, click 'Install'.

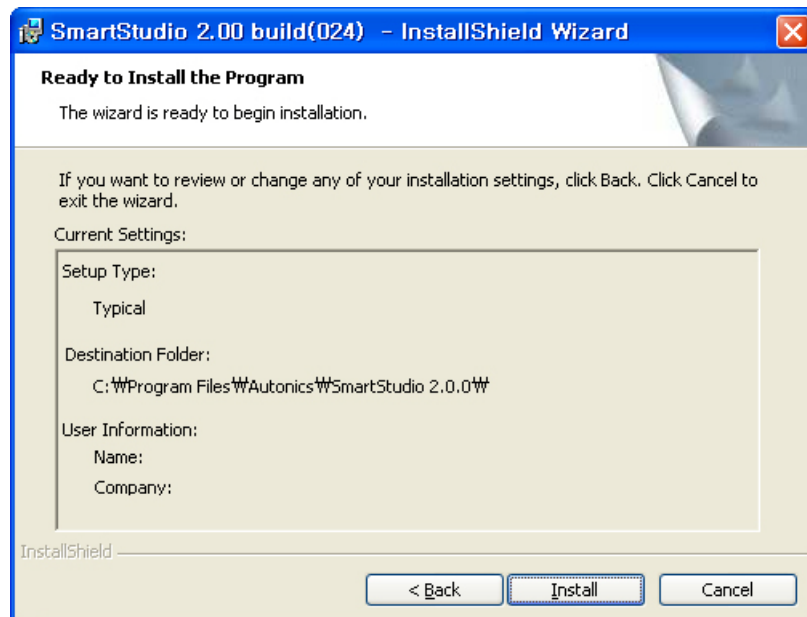

5th Installation starts and you can check installation progress at the same time. After completing installation, click 'Finish' and SmartStudio runs.

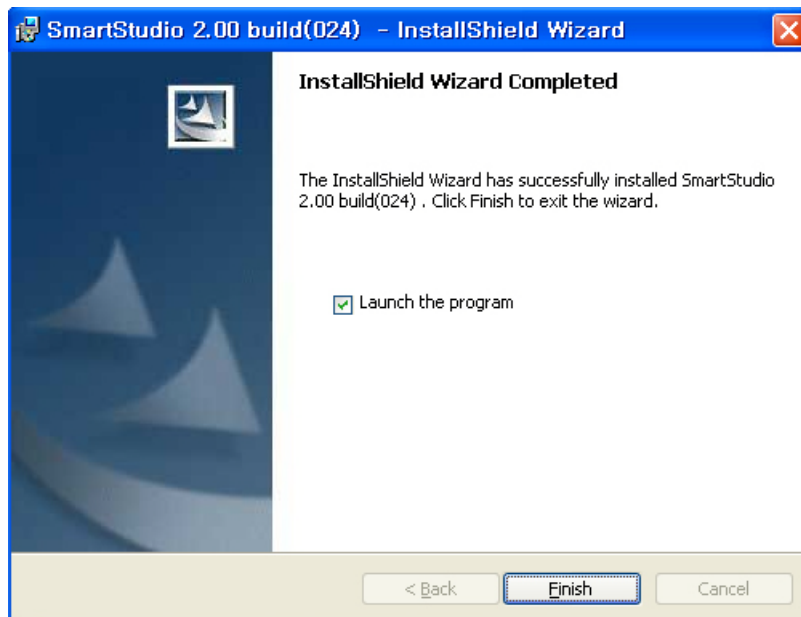
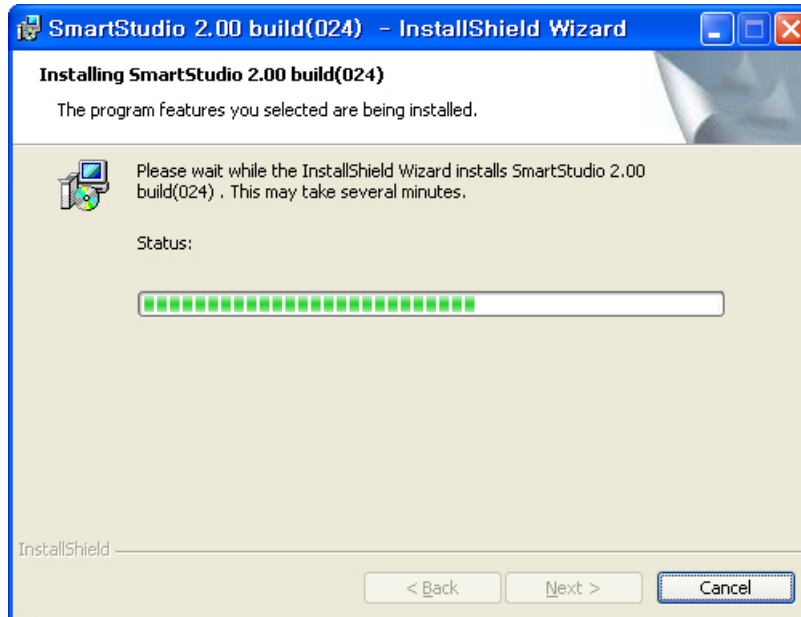

1.4 SmartStudio Screen Layout

SmartStudio consists of menu, toolbar, workspace, program, parameter, variable/comment, monitoring edit windows, message, and status bar.

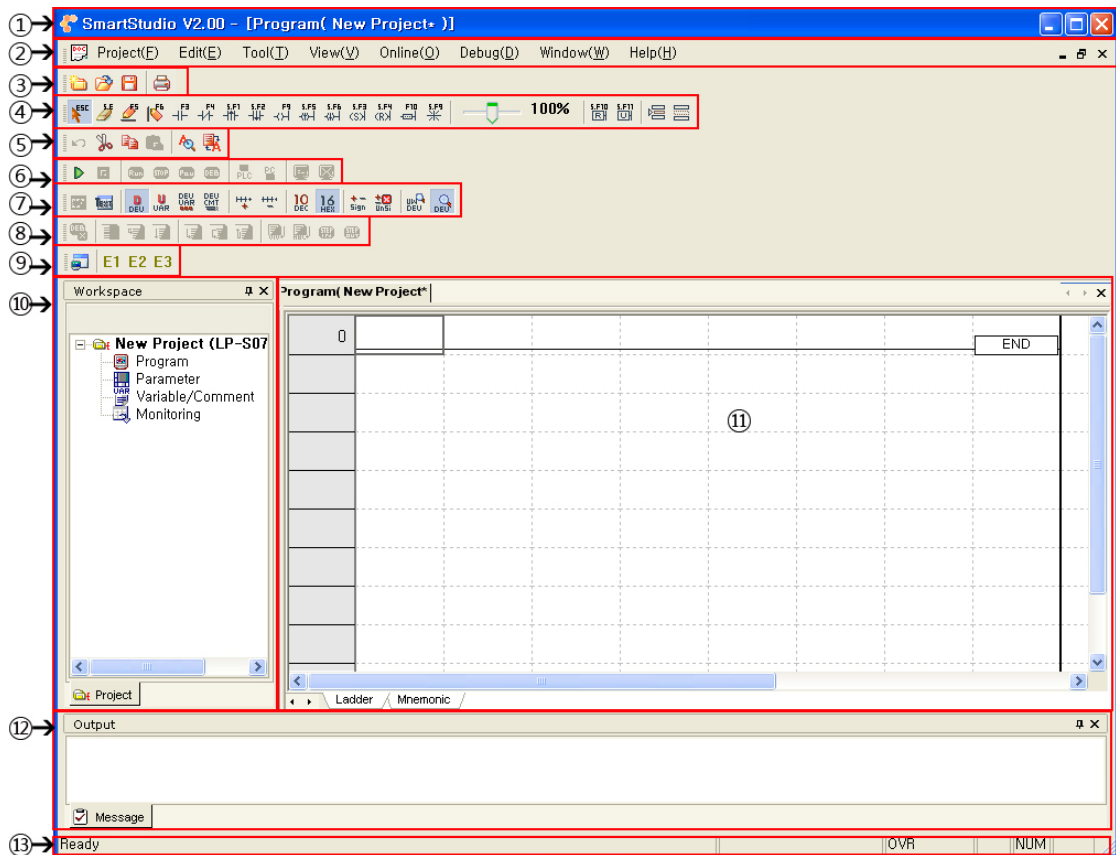

No.	Name	Description
①	Title bar	Displays SmartStudio version and the activated project title.
②	Menu	Menu for all SmartStudio functions by each item.
③	Project tool	Tool for project menu
④	Ladder tool	Tool for ladder program
⑤	Edit tool	Tool for editing such as cut, copy or paste
⑥	Online tool	Tool for communication between SmartStudio and LP
⑦	View tool	Tool for viewing the desired information in SmartStudio
⑧	Debug tool	Tool for debugging the program after connecting SmartStudio and LP
⑨	External program connection	Executes external program directly in SmartStudio
⑩	Work space	Displays the project structure and the activated project
⑪	Program, parameter, variable/comment, monitoring edit window	You can edit the program(ladder/mnemonic) of activated project, the setting of parameter, variable/comment, and check monitoring.

No.	Name	Description
⑫	Message	Displays messages during operating project
⑬	Status bar	Displays LP operation status, edit mode status, NumLock key status

1.4.1 Menu

There are project, edit, tool, view, online, debug, window, and help menus.

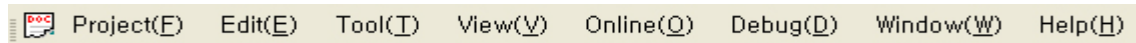

(1) Project

Project menu is for overall project management.

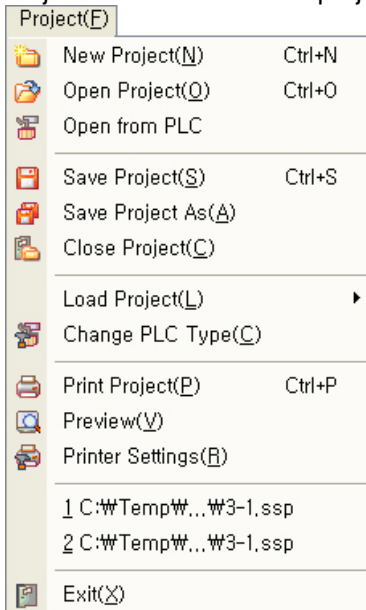

Menu	Function	Hot key	Icon
New Project	Creates a new project.	Ctrl + N	
Open Project	Opens an existing project.	Ctrl + O	
Open from PLC	Creates a new project by uploading a project stored in LP.		
Save Project	Saves a project.	Ctrl + S	
Save Project As	Saves a project as a different name.		
Close Project	Closes the project.		
Load Project	Creates a new project while the current project remains open for editing. Loads project with 'New Project', 'Saved Project' or 'Open from PLC' menu		
Change PLC Type	Changes LP type of the project open for editing.		
Print Project	Prints the contents of the project you are currently working on.	Ctrl + P	
Preview	Previews the to be printed contents of the project before printing		
Printer Settings	Configures the printer before printing the		

Menu	Function	Hot key	Icon
	project.		
Recent Projects	Displays up to 4 most recently worked on project names.		
Exit	Exits SmartStudio		

(2) Edit

Edit menu is for program editing such as cut, copy, and paste.

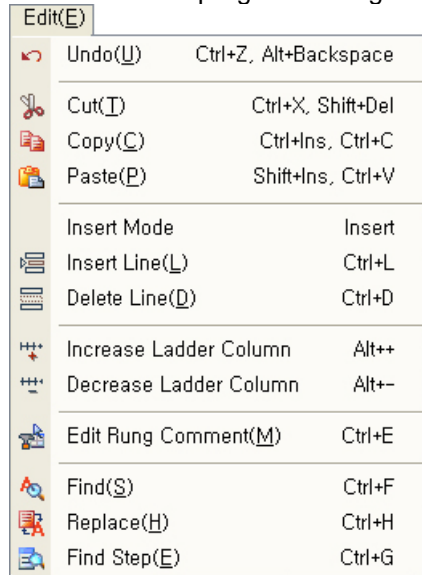

















Menu	Function	Hot key	Icon
Undo	Cancels last edited contents and reverts to the previous state.	Ctrl + Z Alt + Backspace	
Cut	Cuts selected content and pastes it to the clipboard.	Ctrl + X Shift + DEL	
Copy	Copies selected content to the clipboard.	Ctrl + Insert Ctrl + C	
Paste	Pastes content from the clipboard and places it on the ladder/mnemonic editor window (Enables this function only in SmartStudio)	Shift + Insert Ctrl + V	
Insert Mode /Edit Mode	Select insert or edit mode when writing the project	Insert	
Insert Line	Inserts a new line into present location.	Ctrl + L	
Delete Line	Deletes the present line.	Ctrl + D	
Increase Ladder Column	Increases the number of columns by 2.	Alt + +	
Decrease Ladder Column	Decreases the number of columns by 2.	Alt + -	
Edit Rung Comment	Edits rung comments at the rung of the present position.	Ctrl + E	
Find	Finds a device or a string in the project and moves it to the applicable location.	Ctrl + F	













Menu	Function	Hot key	Icon
Replace	Finds a device or a string and changes it with the desired device or string.	Ctrl + H	
Find Step	Moves to a desired step.	Ctrl + G	





(3) Tool

Tool menus are divided into the ladder tools and program checkup menus.

Tool(T)		
	Arrow(A)	Esc
	Delete	Shift+E
	Vertical Line	F6
	Horizontal Line	F5
	Normally Open Contact(Q)	F3
	Normally Closed Contact(C)	F4
	Rising Input Contact	Shift+F1
	Falling Input Contact	Shift+F2
	Output Instruction(O)	F9
	Rising Output Contact	Shift+F5
	Falling Output Contact	Shift+F6
	SET	Shift+F3
	RESET	Shift+F4
	Application Instructions(P)	F10
	NOT Instruction(V)	Shift+F9
	Register User Defined Function(N)	Shift+F10
	User Defined Function(E)	Shift+F11
Program Checking ▶		

Ladder tool menu is for writing ladder program.

Menu	Function	Hot key	Icon
Arrow	Selects ladder objects.	ESC	
Delete	Erases the selected ladder cell.	Shift + E	
Vertical Line	Enters a vertical line into the ladder cell.	F6	
Horizontal Line	Enters a horizontal line into the ladder cell.	F5	
Normally Open Contact	Enters a normal open contact into the ladder cell.	F3	
Normally Closed Contact	Enters a normal close contact into the ladder cell.	F4	
Rising Input Contact	Enters a rising input contact point into the ladder cell.	Shift + F1	
Falling Input Contact	Enters a falling input contact point into the ladder cell.	Shift + F2	
Output Instruction	Enters an output instruction into the ladder cell.	F9	
Rising Output Contact	Enters a rising output coil into the ladder cell.	Shift + F6	
Falling Output Contact	Enters a falling output coil into the ladder cell.	Shift + F5	
SET	Enters a SET instruction into the ladder cell.	Shift + F3	

Menu	Function	Hot key	Icon
RESET	Enters a RESET instruction into the ladder cell.	Shift + F4	
Application Instruction	Enters an application instruction into the ladder cell.	F10	
NOT Instruction	Enters a NOT instruction into the ladder cell.	Shift + F9	
Register User Defined Function	Registers the block designated rung as a user defined function	Shift + F10	
User Defined Function	Uses the registered user defined function	Shift + F11	

Program Checking menu has submenus for program optimization and checking.

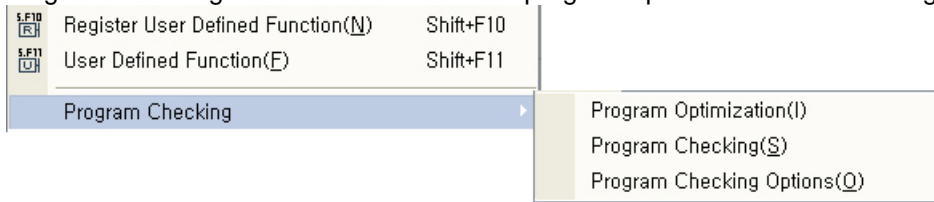

Menu	Function	Hot key	Icon
Program Optimization	Optimizes the program.		
Program Checking	Performs program checking. The result is shown in a message window.		
Program Checking Options	Select processing dual coil as error or not during program checking		

(4) View

View menu has the functions to be set by users, in order to view information on SmartStudio screen.

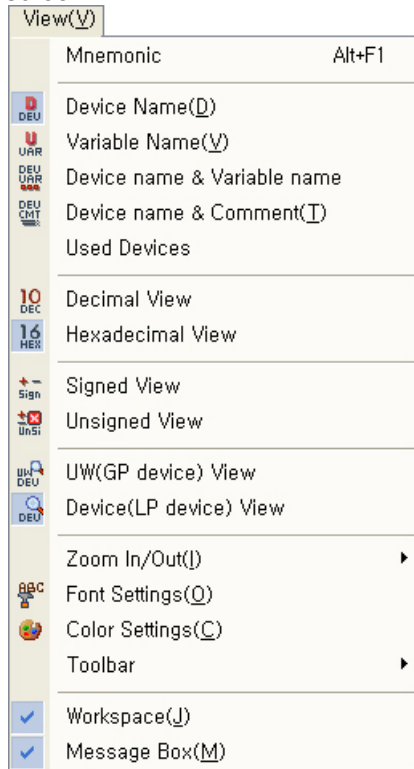

Menu	Function	Hot key	Icon
Ladder/Mnemonic	Exchanges ladder or mnemonic window		
Device Name	Shows device name on the program window.		
Variable Name	Shows variable name on the program window		
Device name & Variable name	Shows device name and variable name together on the program window.		
Device name & Comment	Shows device name and description together on the program window.		
Used Devices	Shows numbers as decimal numbers.		
Decimal View	Shows numbers as hexadecimal numbers.		
Hexadecimal View	Shows decimal numbers as signed numbers.		
Signed View	Shows decimal numbers as unsigned numbers.		
Unsigned View	Shows devices used in the program as GP(UW) devices.		
UW (GP device) View	Shows devices used in the program as LP devices.		
Device (LP device) View	Increases or decreases the screen size.		
Zoom In/Out	Shows device name on the program window.		
Font Settings	Sets the font of program		

Menu	Function	Hot key	Icon
Color Settings	Sets the color for ladder editor.		
Toolbar	Shows toolbar		
Workspace	Shows workspace.		
Message Box	Shows message box.		

(5) Online

Online menu contains functions related to communications between SmartStudio and LP.

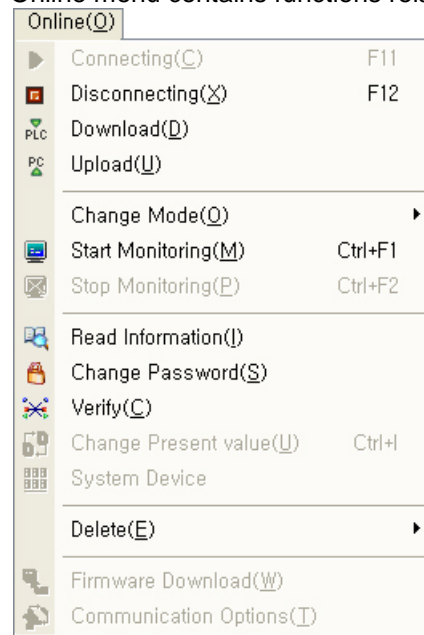









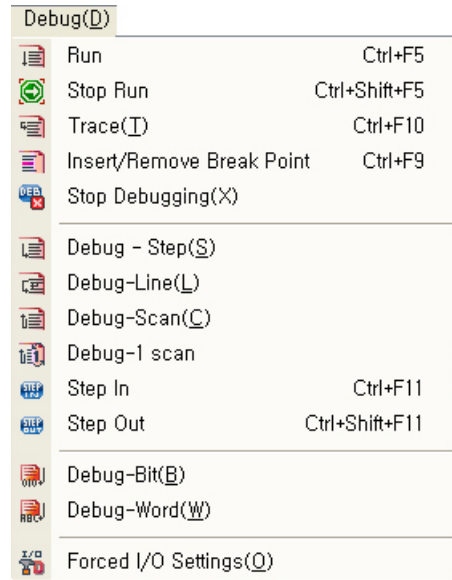

Menu	Function	Hot key	Icon
Connecting	Attempts to connect between SmartStudio and LP.	F11	
Disconnecting	Ends the connection between SmartStudio and LP.	F12	
Download	Downloads programs and parameters written in SmartStudio to LP system.		
Upload	Uploads programs and parameters stored in LP to SmartStudio.		
Change Mode	Changes the mode of LP system.		
Start Monitoring	Monitors LP system from SmartStudio.	Ctrl + F1	
Stop Monitoring	Stops LP system monitoring from SmartStudio.	Ctrl + F2	
Read Information	Checks information about LP system.		
Change Password	Changes password of the LP system. Default is not set. If you lost the password, notify Autonics of the password.		
Verify	Verifies whether the contents written in SmartStudio match the ones in LP or not.		
Change Present value	Changes present values of LP system devices.	Ctrl + I	
System Device	Monitors LP system devices in batches.		
Delete	Erases data on LP system.		

Menu	Function	Hot key	Icon
Firmware Download	Download firmware to LP system by SmartStudio. (Only for LP-S044 series.)		
Communication Options	Changes communication setting of SmartStudio		

(6) Debug

Debug menu are functions for program debugging after editor and LP communication is connected.



Menu	Function	Hot key	Icon
Run	Runs the program in debug mode.	Ctrl + F5	
Stop Run	Stops running the program in debug mode.	Ctrl + Shift + F5	
Trace	Debugs the program on an instruction basis.	Ctrl + F10	
Insert/Remove Break Point	Inserts or removes break at the relevant points.	Ctrl + F9	
Stop Debugging	Stops the debugging.		
Debug-Step	Debugs up to a specified step.		
Debug-Line	Debugs as specified lines.		
Debug-Scan	Debugs as specified scan chains.		
Debug-1 scan	Debugs only 1 scan.		
Step In	Moves debug point into sub-routines or user defined functions.	Ctrl + F11	
Step Out	Moves debug point from the present position to the main program.	Ctrl + Shift + F11	
Debug-Bit	Debugs until a specified bit has reached the set value.		
Debug-Word	Debugs until a specified word has reached the set value.		
Forced I/O Settings	Forces present value setting of input/output device of LP system.		

(7) Window

Window menu are functions for aligning the program window and monitoring window in the program, and for connecting external programs.

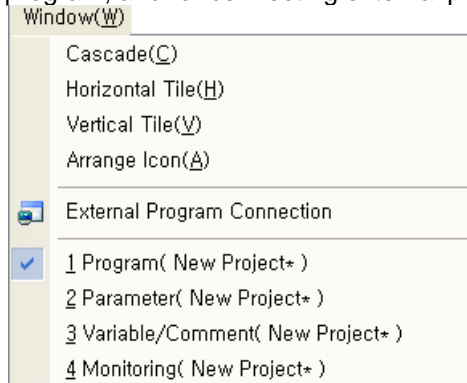

Menu	Function	Hot key	Icon
Cascade	Arranges opened windows in the program in a tiled view.		
Horizontal Tile	Arranges opened windows in the program in horizontal boards.		
Vertical Tile	Arranges opened windows in the program in vertical boards.		
Arrange Icon	Aligns minimized open windows in the program.		
External Program Connection	Registers external programs in order to run them in SmartStudio.		

(8) Help

Help menu contains for SmartStudio's information.

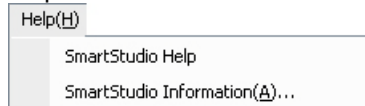

1.4.2 Toolbar

You can arrange the icons for your convenient.



Toolbar	Icon
Project tool	
Ladder tool	
Online tool	
Edit tool	
View tool	
Debug tool	
External program connection	

1.4.3 Work space

Displays project structure and currently active projects.

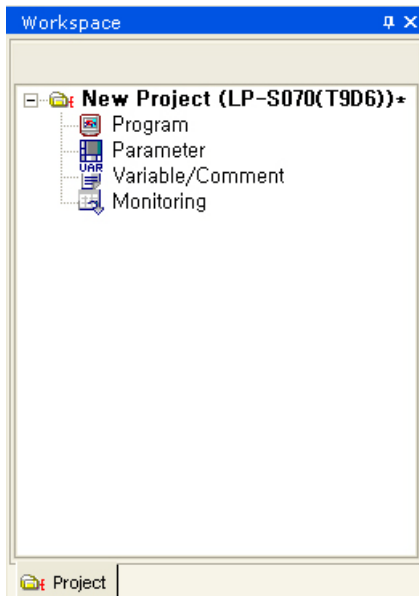

1.4.4 Message box

Displays message to display during program operation.



1.4.5 Status bar

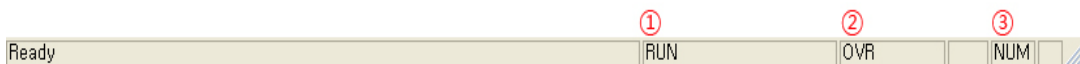

Status bar	Description
① LP operation status	Displays system operation status while communications with the system are connected. The system operation status could be one of RUN, STOP, PAUSE, DEBUG, and H/W STOP.
② Edit mode of ladder/mnemonic editor	Indicates the edit mode of the ladder editor or mnemonic editor. Edit mode is indicated as one of Edit or OVR.
③ NumLock key status	Displays the status of NumLock key on the number pad.

2 Project

2.1 New project

Creates a new project.

Select [Project]-[New Project] of menu, and 'Project Information' dialog box appears.

Project information	Description
① PLC series	Select the series of the device by pull-down menu.
② PLC type	Select the type of the series by pull-down menu.
③ Ladder/ Mnemonic	Select a programming language for the new project.
④ Written Date	Enter the date created. The default is set to today's date.
⑤ Title	Enter the title.
⑥ Company	Enter the company name.
⑦ Writer	Enter the writer
⑧ Comment	Enter a brief project comment.
⑨ OK	Create a new project
⑩ Cancel	Cancel creating a new project.



Note

④ to ⑧ are not required fields and do not affect project creation.

2.2 Open project

Opens a saved project. Select [Project]-[Open Project] of menu and 'Open' dialog box appears. Select SmartStudio's the project (extension: *.ssp) file and click 'Open'. The project file opens in SmartStudio.

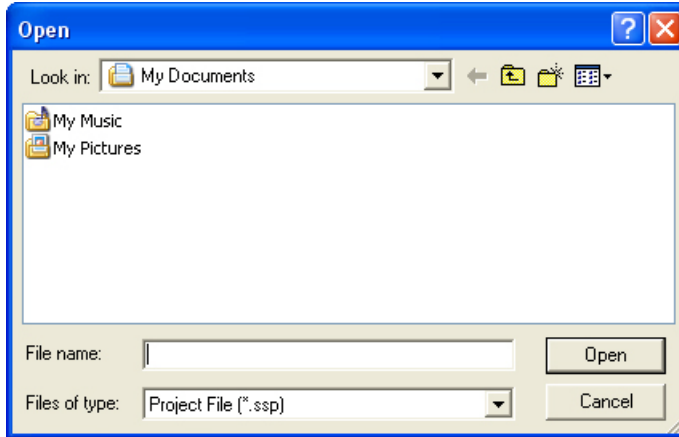

2.3 Open from PLC

This feature closes all open projects and performs connection and upload consecutively. Therefore, communication with the system should not be connected to enable the menu.

It loads the project which is from LP and creates the new project. Select [Project]-[Open from PLC].

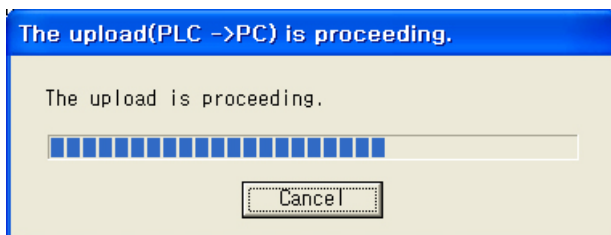

When the connection fails, it shows a message of failure and stops. If this is the case, check the communication option in [Online]-[Communication Option] of menu.



Note

To read the contents of LP into currently open project, select [Online]-[Upload] of menu.

2.4 Save project

Saves the edited project.

Select [Project]-[Save Project] of menu. If the project is already saved, it is saved in the present project file which has same file name.

If the project is saved for the first time, 'Save As' dialog box appears.

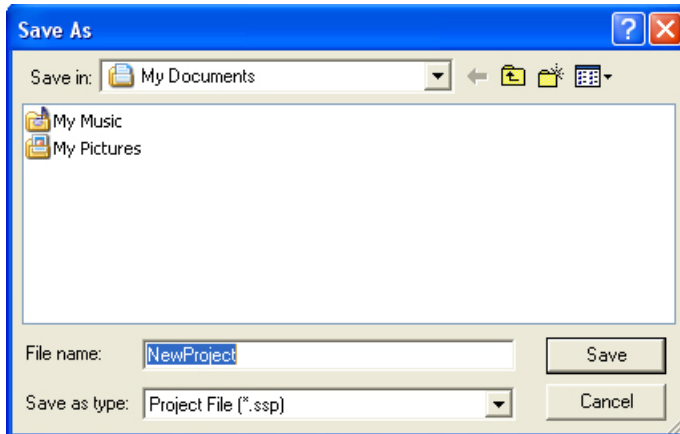

Specify the path, enter the file name, and click 'Save' to save the current project.



Note

If the project is a newly created one, or there are changes to the project since it saved last time, the project name in the workspace displays with * at the end as shown inside a red circle in the image below.

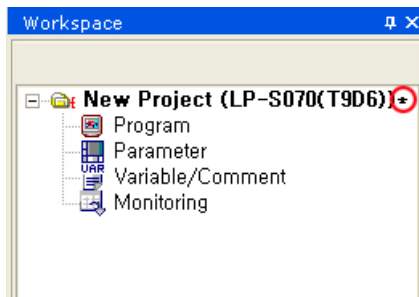

2.5 Save Project As

Saves creating or created project as a different name.

Select [Project]-[Save Project As] of menu and 'Save As' dialog box appears as following figure.

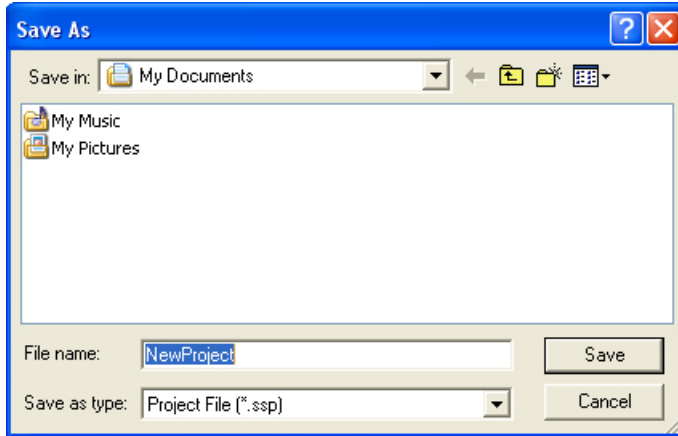

Specify the path enter the file name and click 'Save' and the current project is saved. The file extension is '*.ssp'.

2.6 Close project

Closes an activated project.

Select [Project]-[Close Project] of menu and it executes as followings.

- If the project is a newly created one or an existing project with changes, it confirms saving or not and then closes the project.
- If the project is not changed since it opened, it closes the project without saving.

2.7 Load project

This function is used to open an additional project while one or more projects are open. Therefore, this menu is activated only when more than one project is open.

2.7.1 New project

Adds a new project to editor.

Select [Project]-[Load Project]-[New Project] of menu and 'Project Information' dialog box appears.

Project information	Description
① PLC series	Select the series of the device by pull-down menu.
② PLC type	Select the type of the series by pull-down menu.
③ Ladder/ Mnemonic	Select a programming language for the new project.
④ Written Date	Enter the date created. The default is set to today's date.
⑤ Title	Enter the title.
⑥ Company	Enter the company name.
⑦ Writer	Enter the writer
⑧ Comment	Enter a brief project comment.
⑨ OK	Create a new project
⑩ Cancel	Cancel creating a new project.



Note

④ to ⑧ are not required fields and do not affect project creation.

After the project is added, the following message appears to activate this project.

Click 'Yes' to activate the added project. Click 'No' or 'Cancel' and the added project is not activated and this project is displayed in workspace.

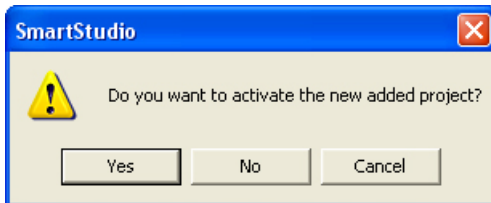

2.7.2 Saved project

Loads saved project and adds the project in SmartStudio.

Select [Project]-[Load Project]-[Saved Project] of menu and 'Open' dialog box appears.

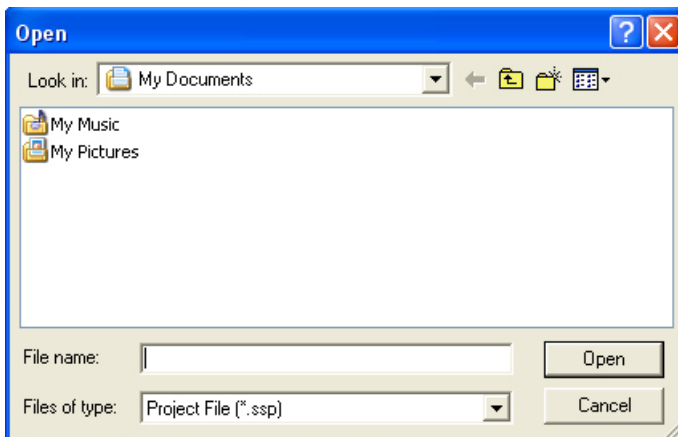

Select SmartStudio's the project (extension: *.ssp) file and click 'Open' and the selected project is added in workspace. After adding the project, the program confirms whether to activate the added project or not.

2.7.3 Open from PLC

This is a feature that performs connection, upload and adds project consecutively. Therefore, this menu is enabled only when the program is not connected to the system.

Opens the project stored in LP and adds it in SmartStudio. Select [Project]-[Load Project]-[Open from PLC] of menu.

If the connection between the editor and system is available, [Open from PLC] menu works and adds the uploaded project to workspace.

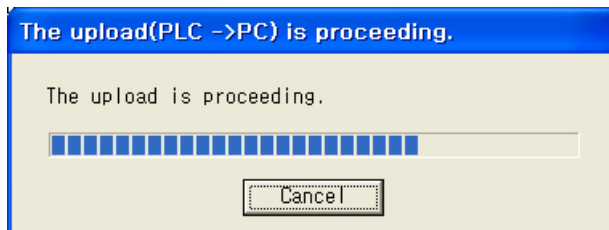

If an uploaded project and an existing project have the same project ID, a message appears and asks the user whether to apply the uploaded project to the project with the same ID, or to add as a new project.

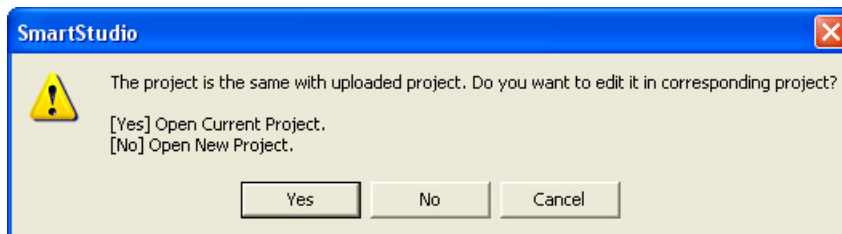

Click 'Yes' to apply the uploaded project information to the project with the same ID. Click 'No' and the uploaded project is added as a new project. Click 'Cancel' and it stops upload operation.

When the project is added, the program confirms whether to activate the added project or not.

2.7.4 Change PLC Type

Select [Project]-[Change PLC Type] of menu and 'Change PLC type' dialog box appears. Select the 'PLC type' to change by pull-down menu and it changes the appropriate device and instructions for the changed PLC.

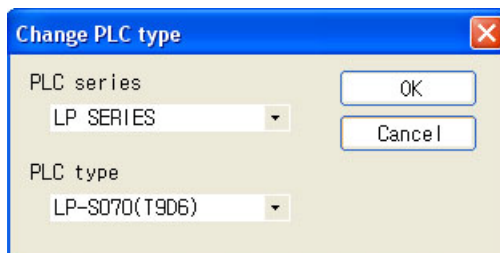

If the devices and instructions are not compatible with the changed model, places for devices or instructions are replaced with"?".

In case of color type (LP-S070) PLC program which supports motion instruction, it does not change to the mono type program and error occurs.

2.8 Print Project

Prints the program.

You can choose to print either parts or the whole of the program that is displayed currently. When printing the parts of the program, you can specify the range of steps to print.

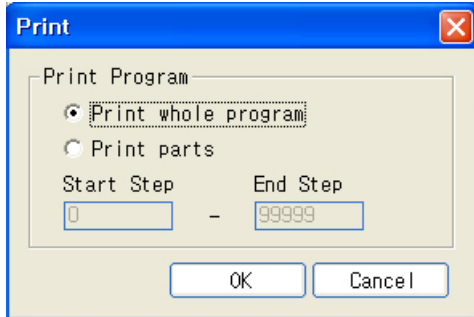

The contents of print preview screen are printed.

2.9 Preview

Shows contents to be printed in currently activated windows, such as [ladder editor, mnemonic editor, parameter, variable/comment]. This is irrelevant to currently active projects.

Select [Project]-[Preview] of menu after activating the to be printed edit window, 'Preview Print' dialog box appears.

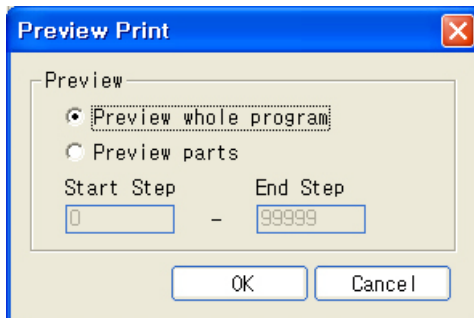

Select a program range to preview.

- Preview whole program: Previews whole program steps.
- Preview parts: Previews from the start step to end step of the program.

**Note**

The following project properties are always printed on the preview screen.

Register Information

Project Registered Information

PLC Series : LP SERIES
PLC Type : LP-S070(T9D6)

Written Date : Dec, 22th, 2011
Title : Preview test
Company : Autonics
Writer :
Comment :

Save intervals for temporary file : 2 (Minute)
(Not save when setting as '0')

The numbers of buffer to undo : 10 (Times)

OK Cancel



Ex.

(1) Preview for program (ladder editor)

Print Next Page Prev Page Two Page Zoom In Zoom Out Close

Ladder Program

0	F00012 ↑↑		MTOBC H001
11	M0000 		MOV H002 M000
17	M0000 /		MOV H001 M000
23	U802000 ↑↑		MTCPP M000 D004
34	U802002 ↑↑	MTPDM M000 D002 D000 H001 H001 H001	
45	U802003 ↑↑	MTPDM M000 D002 D000 H001 H001 H001	
56	U802004 ↑↑		MTOVP M000 D004
67	U802005 ↑↑		MTOVP H001 H000E2
78	U802006 ↑↑	MTPDM M000 U802005 D006 H001 H001 H001	
89	U802007 ↑↑		MTRRS M000
100	U802008 ↑↑		MTOVW M000 D008
111	U802009 ↑↑		MTUAI M000 D000
122	U802010 ↑↑		MTPQS M000
133	U802011 ↑↑		MTOBC M000
144	U802012 ↑↑		MTIDM M000 D002
155	U803000 ↑↑		MTRBC H001
166	U803001 ↑↑		MTRBC H002
177	U803100 ↑↑		MTRMS H001

Program :	
Company :	Writer :
Date :	Page : 1/2

(2) Preview for program (mnemonic editor)

Mnemonic Program				
Step	Instruction	Device	Variable	Comment
0	LOADP	F00012	FV_0012	1 SCAN ON
2	MTOBC	H0001		
11	LOAD	M00000		
12	MOV	H0002		
		M0050		
17	LOADN	M00000		
18	MOV	H0001		
		M0050		
23	LOADP	UB02000		
25	MTCPP	M0050		
		D0064		
34	LOADP	UB02002		
36	MTPDM	M0050		
		D0052		
		D0050		
		H0001		
		H0001		
		H0001		
45	LOADP	UB02003		
47	MTPDM	M0050		
		D0052		
		D0050		
		H0001		
		H0001		
		H0001		
56	LOADP	UB02004		
58	MTOVP	M0050		
		D0054		
67	LOADP	UB0200A		
Program :				
Company :			Writer :	
Date :			Page : 1/3	

(3) Preview for parameter

Print	Next Page	Prey Page	Two Page	Zoom In	Zoom Out	Close
-------	-----------	-----------	----------	---------	----------	-------

Parameter	
1. Parameter : Common Items	
(1) Output Option : Output after completing which it scans (2) Default filter price : 0 msec (3) Expansion module function operational condition : Only run mode operation (4) Settlement flag operation : not use (5) Latch device set > D : 1000 ~ 9999 > M : 1000 ~ 9999 > T : 128 ~ 255 > C : 128 ~ 255 > S : 128 ~ 255 > R : 0 ~ 3999 > L : 500 ~ 999 (6) Time Interrupt > TINT[1] :: Time(0*10ms) > TINT[2] :: Time(0*10ms) > TINT[3] :: Time(0*10ms) > TINT[4] :: Time(0*10ms) > TINT[5] :: Time(0*10ms) > TINT[6] :: Time(0*10ms) > TINT[7] :: Time(0*10ms) > TINT[8] :: Time(0*10ms) (7) Timer scope set > 100ms :: 127 ~ 127 > 10ms :: 255 ~ 255	
2. Parameter : Expansion set	
Slot No : 0 Module : IN16/OUT16 Version : DEFAULT (1) FILTER Set > Not Use (2) Interrupt Set > Not Use	
Program :	
Company :	Writer :
Date :	Page : 1/25

2.10 Printer settings

Configures the printer to be used.

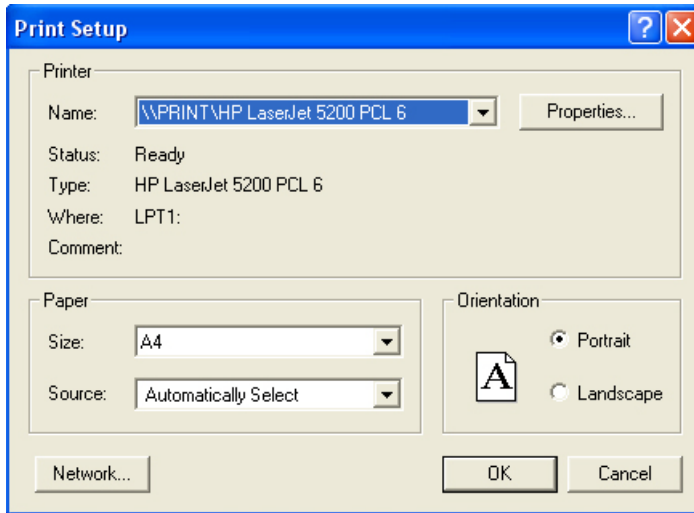

2.11 Exit

Exits SmartStudio.

If there is any unsaved project, the dialog box appears to check saving the project. Click 'Yes' and it saves and exits SmartStudio.

3 Edit

3.1 Undo

Select [Edit]-[Undo] of menu or press Ctrl+Z keyboard and the most recent operation is cancelled.

You can designate the numbers of undo at 'The numbers of buffer to undo' in 'Project Registered Information' in workspace. Click the project menu with right mouse button in workspace and the following pop-up menu appears.

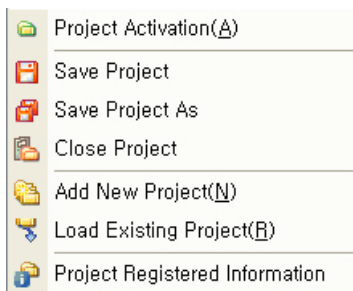

Select [Project Registered Information] of pop-up menu, 'Register Information' dialog box appears as following.

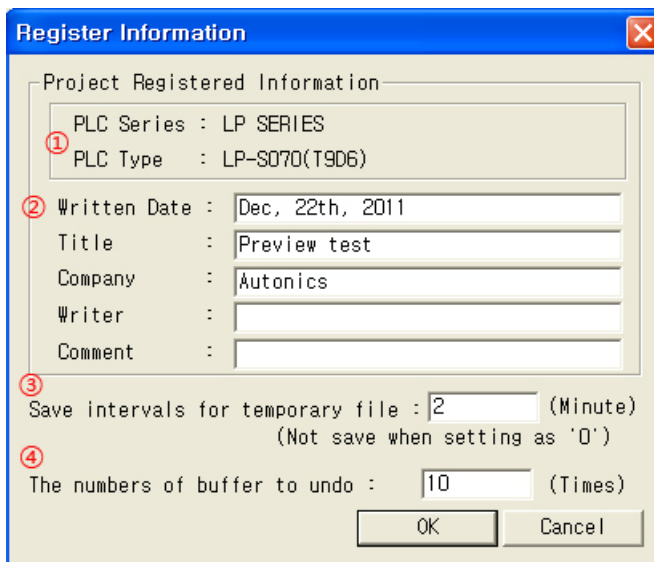

Register information	Description
① PLC series/ PLC type	Shows LP series and type of present project.
② Written date /Title /Company /Writer /Comment	Enters the additional information of the project.
③ Save intervals for temporary file	Designates the saving interval of temporary files. If this value is set to 0, temporary files are not saved. (Temporary files are saved in the installed SmartStudio program 'Autonics\SmartStudio 2.00\Temp' location.)
④ The numbers of buffer to undo	Designates the number of undo. (Setting range: 1 to 99)

3.2 Cut

Select the to be cut area and select [Edit]-[Cut] of menu or press Ctrl+X keyboard and the selected area is cut and saved in the clipboard.

The following is the example of cut instruction in ladder editor.

- Before cut

Select a block to cut a certain area. You can select a cell instead of a block.

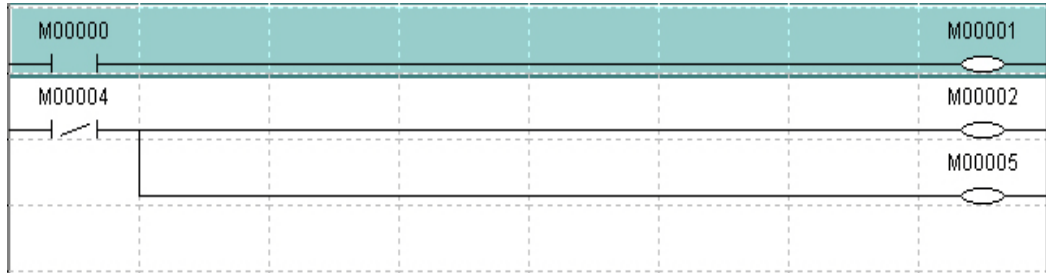

- After cut

After cut instruction, the selected area disappears from the screen. It is copied to the clipboard.

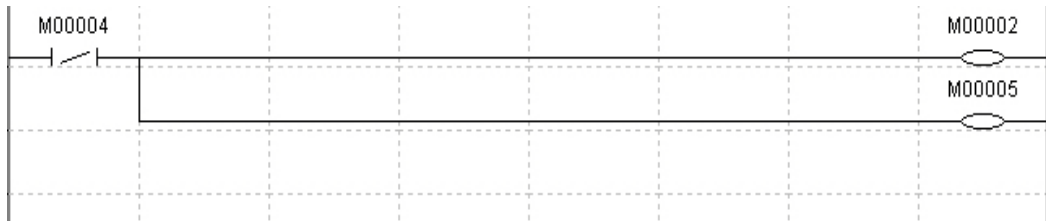

- After paste

The content copied to the clipboard is pasted to a selected cell.

Select [Edit]-[Paste] of menu or press Ctrl+V keyboard.

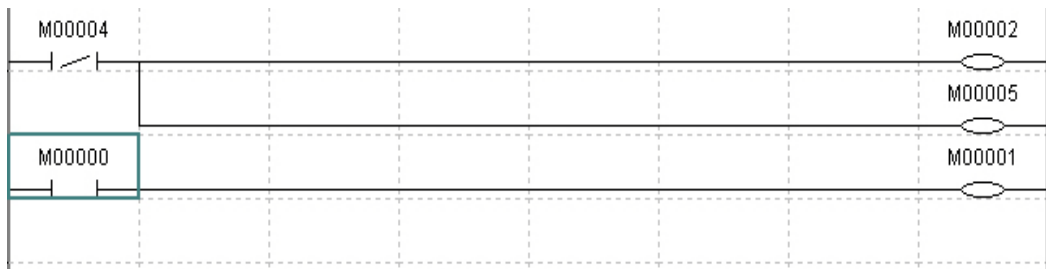

3.3 Copy

Select the to be copied area and select [Edit]-[Copy] of menu or press Ctrl+C keyboard and the selected area is copied in the clipboard.

The following is the example of copy instruction in ladder editor.

- Copy

Select a block to copy a certain area. The screen does not show any change.

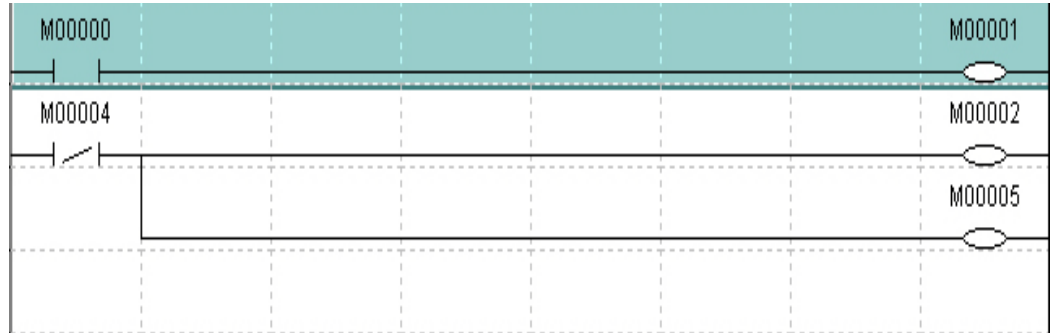

- Paste

The content copied is pasted to a selected cell.

Select [Edit]-[Paste] of menu or press Ctrl+V keyboard.

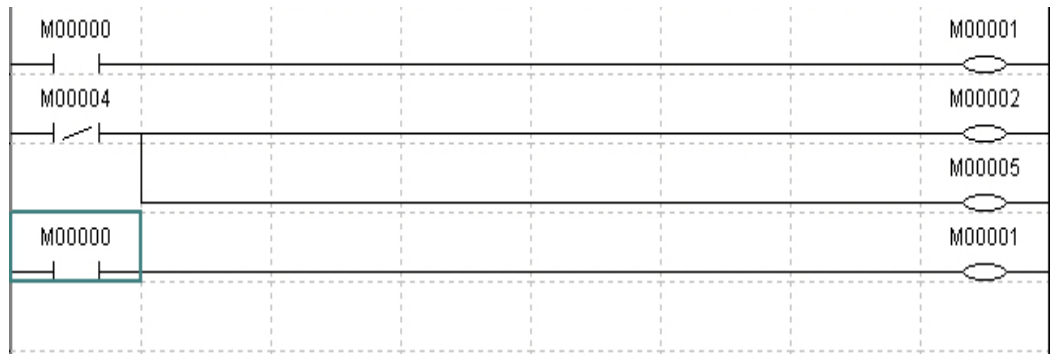

3.4 Paste

Select the desired area to be pasted and select [Edit]-[Paste] of menu or press Ctrl+V keyboard and [Cut] or [Copy] area is pasted to the selected area or the designated part.

3.5 Insert mode/Edit mode

Whenever selecting [Edit]-[Insert Mode], [Insert Mode] or [Edit Mode] is set alternatively for ladder editor.

Insert mode	Program entry pushes out the cell or line that is on the cursor position. In insert mode, the cursor changes to a green dotted line.
Edit mode	Program entry deletes and replaces the cell or line that is on the cursor position. In insert mode, the cursor changes to a green line.

3.6 Insert line

Inserts a new line into the present cursor location.

Move the cursor to the position you want to add a line, and select [Edit]-[Insert Line] or press Ctrl+L keyboard. A new line is added to the cursor position.

The following is the example of insert line instruction in ladder editor.

In case of ladder editor, a line cannot be inserted if there is a instruction that occupies more than two lines at the cursor position. If the horizontal line is inserted in a cell divided by vertical lines, vertical columns are automatically created so that it conforms to the upper and lower lines.

- Before insert

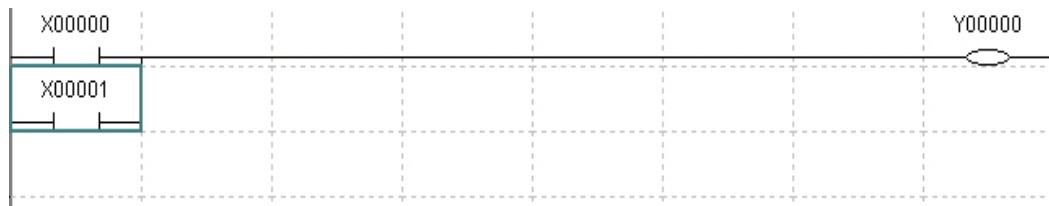

- After insert



- In case of unable to insert

If there is an existing instruction across two lines as the following figure, a new line cannot be inserted to the line where the cursor is placed.

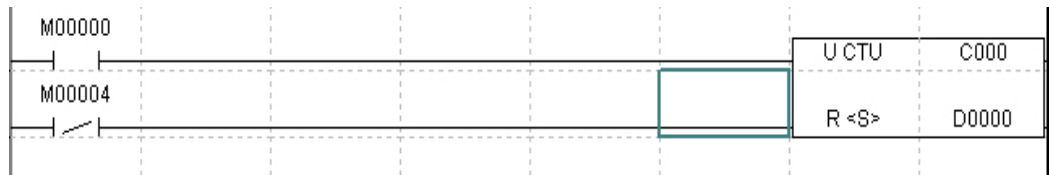

3.7 Delete line

Deletes the line or block where the cursor is placed.

Block the area or place the cursor on the line where you want to delete and select [Edit]-[Delete Line] of menu or press Ctrl+D keyboard. It deletes the desired line.

The following is the example of delete line instruction in ladder editor.

- Before delete



- After delete

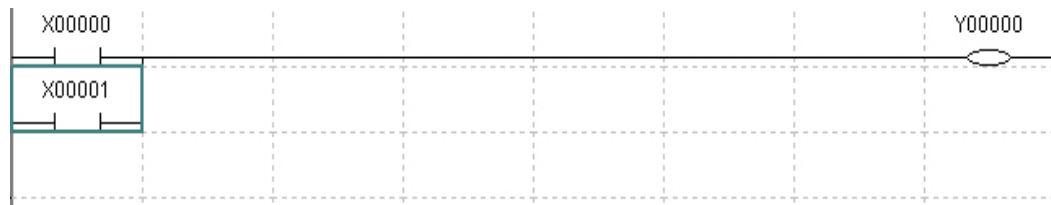

- In case of unable to delete

If there is an existing instruction across two lines as the following figure, the line where the cursor is placed cannot be deleted.

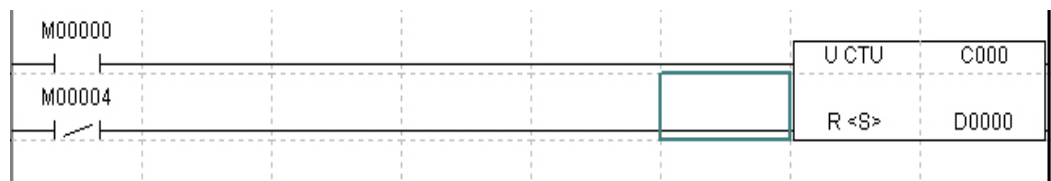

3.8 Increase ladder column

This function increases the number of columns displayed on the ladder editor.

Select [Edit]-[Increase Ladder Column] of menu or press Alt + '+' keyboard and present number of columns + 2 columns is displayed. Maximum number of columns allowed to increase to is 32.

Output instruction is displayed on the right side as the number of increased columns.

- Before increase ladder column

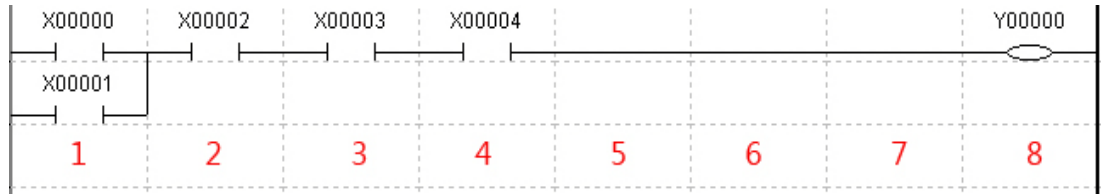

- After increase ladder column



If a ladder has created a wider than indicated number of columns, and an arrow appears as a result, increasing the number of columns makes the arrow disappear and a program can be shown in a line.

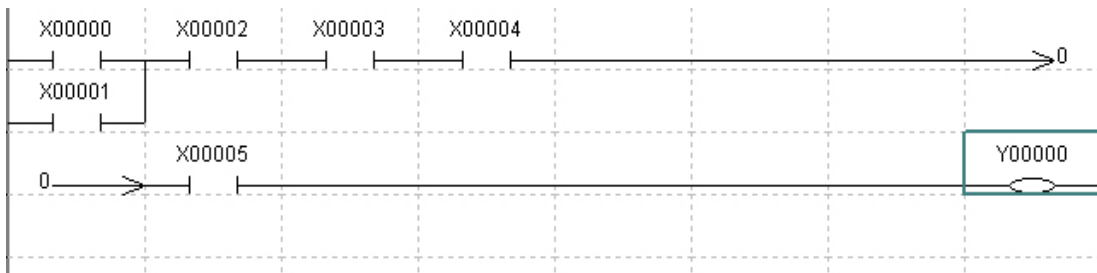

3.9 Decrease ladder column

This function decreases the number of columns that are displayed on the ladder editor.

Select [Edit]-[Decrease Ladder Column] of menu or press Alt + '-' keyboard. Present number of columns minus 2 columns is displayed. Minimum number of columns allowed to keep is 8.

Output instruction is displayed on the right side as the number of decreased columns.

- Before decrease ladder column



- After decrease ladder column

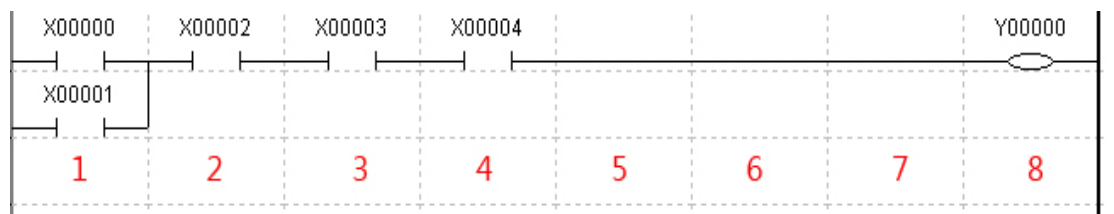

If the input instruction overlaps the output instruction that displays the decreased number of columns (present number - 2), an arrow appears on the last column of the input instruction line and also on the first column of the next line. Output instruction is displayed on the last column of the next line.

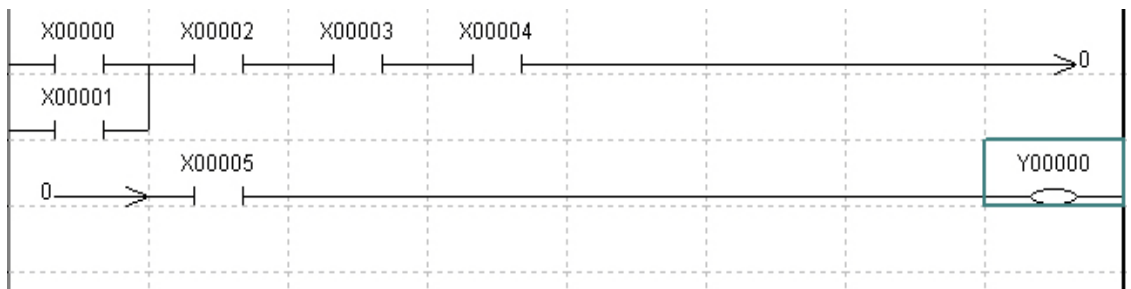
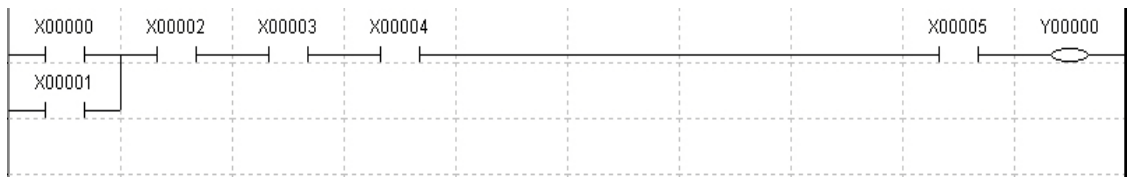

3.10 Edit rung comment

Edits the comment of the rung where the cursor is placed.

Select [Edit]-[Edit Rung Comment] of menu or double-click the desired line to edit the rung comment. Rung comment edit area appears and you can edit the rung comment. Press Ctrl + E keyboard and it operates as same.

The following is the example of edit rung comment instruction in ladder editor.

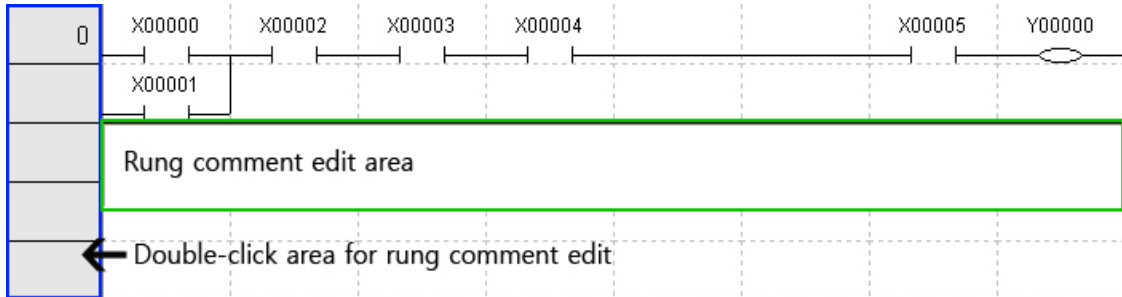

You can enter a maximum 127 byte characters. Press Ctrl+Enter keyboard in rung comment edit area and it is used as a forced line break.

3.11 Find

Finds a string or text in the program.

Select [Edit]-[Find] of menu, or press Ctrl + F keyboard and 'Find' dialog box appears.

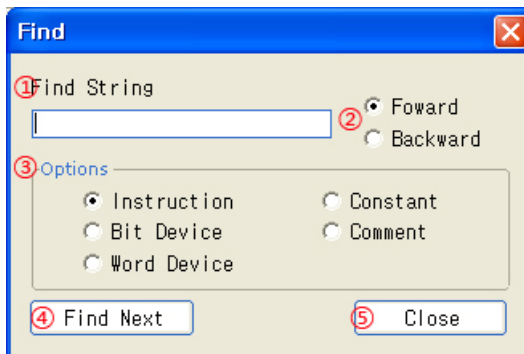

Find	Description
① Find String	Enter the text you want to find.
② Forward/ Backward	Select the direction to find, either forward or backward from the present cursor position.
③ Options	Select the target to find. You can select one of options such as instruction, constant, bit device, comment, or word device.
④ Find Next	Finds the next for the nearest from the present cursor in find direction.
⑤ Close	Finishes find and closes 'Find' dialog box.

If the text is not found or the search reaches the last step, the following dialog box appears.





Ex.

The following is the example of find instruction in ladder editor.

If the text is found, the cursor is placed on the cell where the text is included as below.

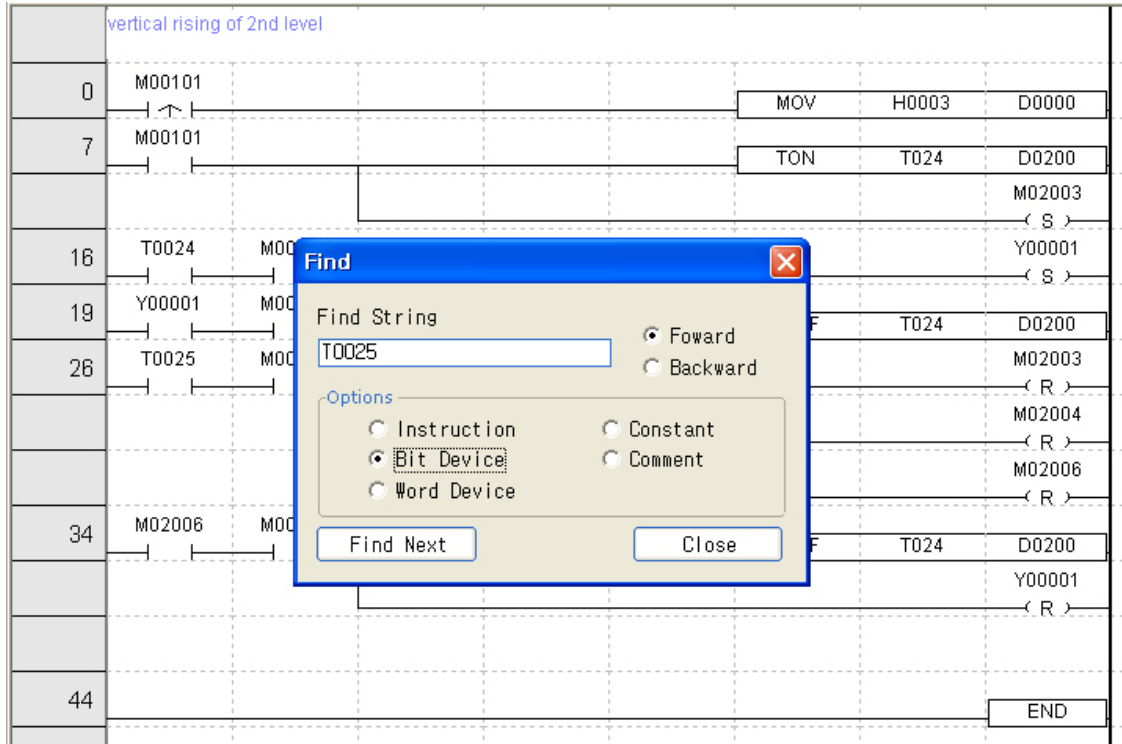

3.12 Replace

Select [Edit]-[Replace] of menu or press Ctrl + H keyboard and 'Replace' dialog box appears.

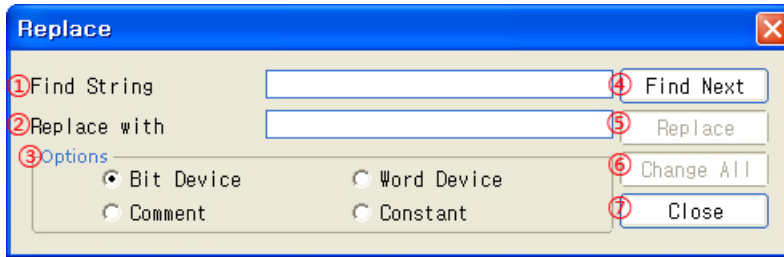

Replace	Description
① Find String	Enter the text to be found
② Replace with	Enter the text to be replaced with ① Find String
③ Options	Select the range of the text to be replaced. You can designate one of bit device, word device, comment, or constant.
④ Find Next	Find ① Find String for the nearest from the present cursor
⑤ Replace	Replaces the finded strings with the replaced strings.
⑥ Change All	Changes all occurrences of the text without confirmation.
⑦ Close	Stops replacing and closes 'Replace' dialog box.

If it cannot find any more of the text, the following dialog box appears.

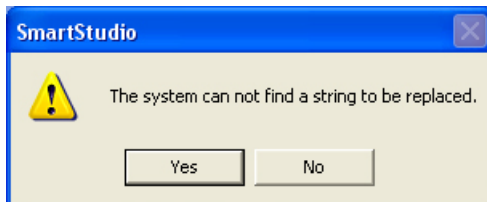

3.13 Find step

Moves cursor to the desired step.

Select [Edit]-[Find Step] of menu or press Ctrl + G keyboard, 'Find Step' dialog box appears.

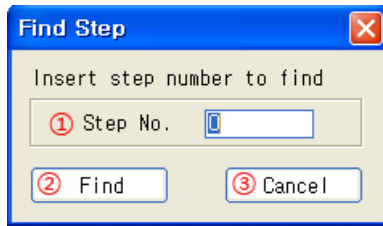

Find step	Description
① Step number	Enter the step number to move.
② Find	Cursor moves to the step entered in ①
③ Cancel	Cancels step finding and closes 'Find Step' dialog box.

If you enter the non-existing step, the following dialog box appears.



4 Tool

4.1 Ladder tool

4.1.1 Arrow

Select [Tool]-[Arrow] of menu or press Esc keyboard in ladder editor, you can select an object and change the cursor position.

You can select a cell or specify a cursor position as the following figure.

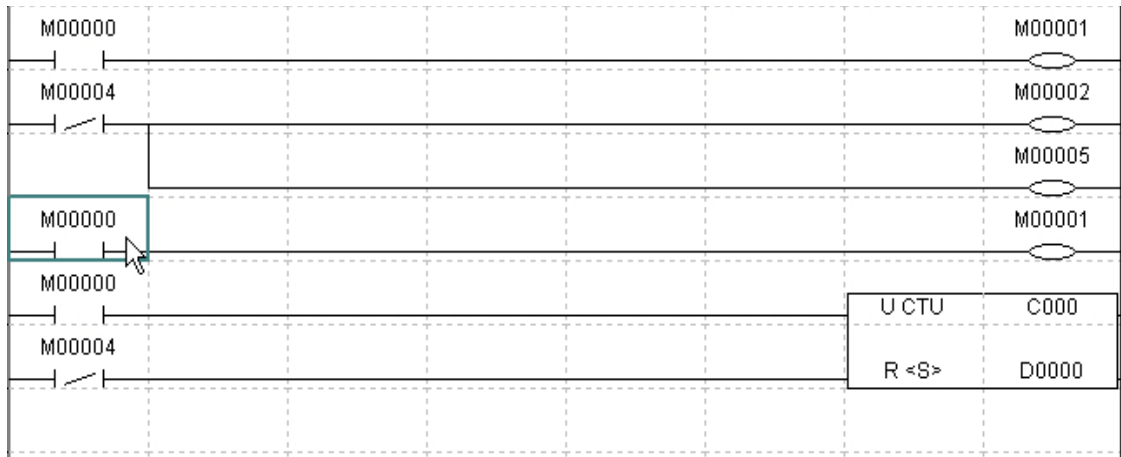

4.1.2 Delete

Select the to be deleted area and select [Tool]-[Delete] of menu or press Shift+E keyboard to delete the object in ladder, mnemonic editor. The following is the example of delete instruction in ladder editor.

If the one cell of the object occupies more than two cells is deleted, the whole object is deleted.

Deleted the object of ladder or mnemonic is restored by [Edit]-[Undo] of menu.

- Before delete

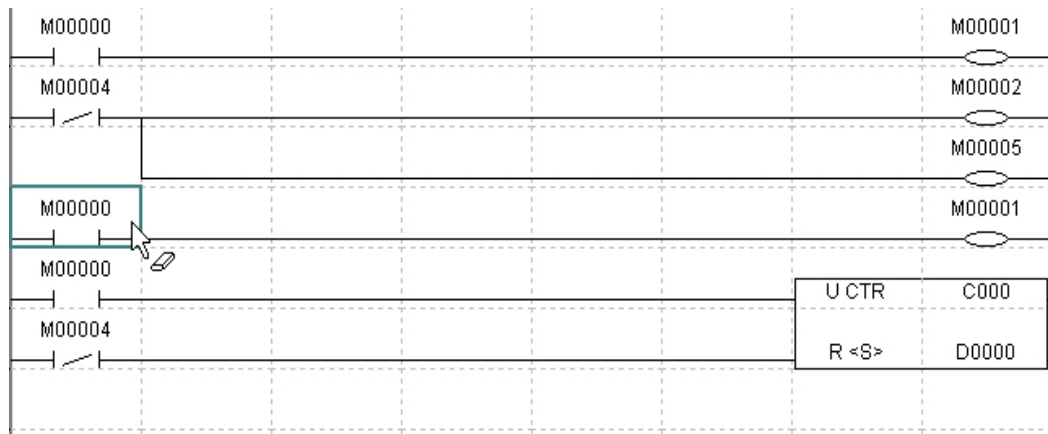

- After delete

You can check the cell where the cursor is placed is deleted.

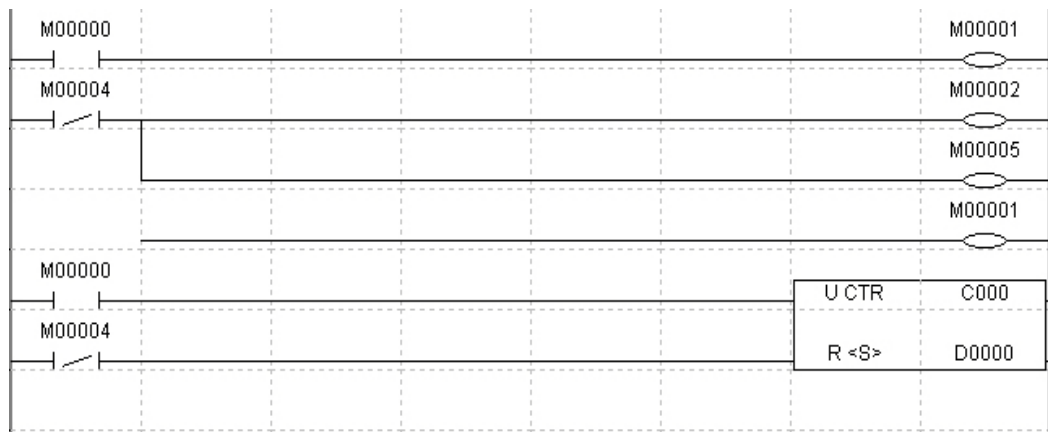

4.1.3 Vertical line

Select [Tool]-[Vertical Line] of menu or press F6 keyboard and it draws a vertical line on the right side of a selected cell in the ladder editor. A vertical line cannot be added on the last column of a ladder line.

- Before editing vertical line

Select [Tool]-[Vertical Line] of menu or press F6 keyboard.

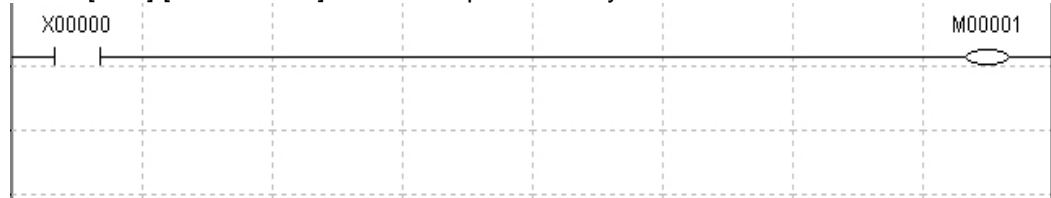

- Edit vertical line

Place the cursor or mouse pointer in the location you want to edit.

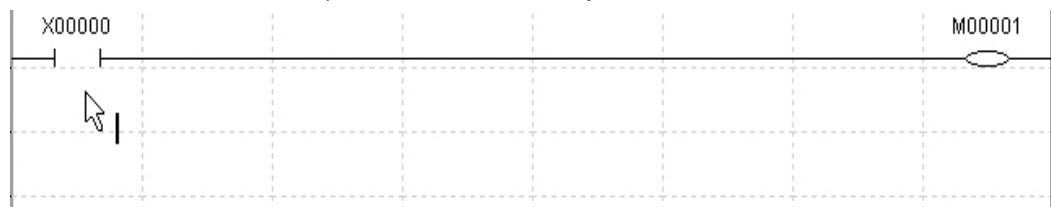

- After editing vertical line

A vertical line is added in the relevant location.

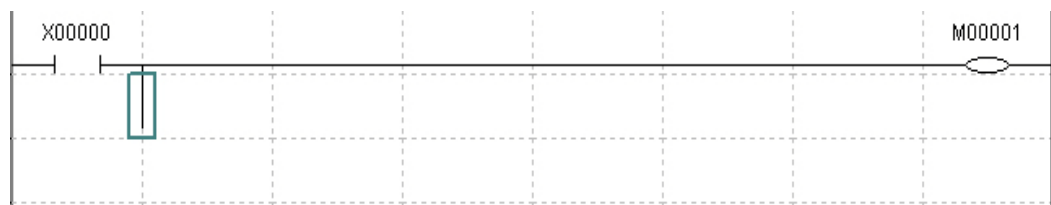

4.1.4 Horizontal line

Select [Tool]-[Horizontal Line] of menu or press F5 keyboard and it draws a horizontal line in the selected cell in the ladder editor. Horizontal line cannot be added in the last column of a ladder line.

- Before editing horizontal line

Select [Tool]-[Horizontal Line] of menu or press F5 keyboard.

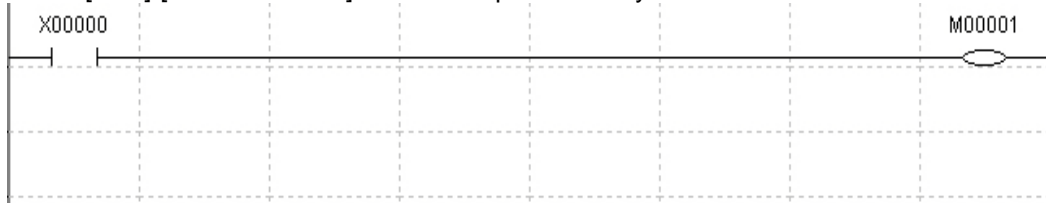

- Edit horizontal line

Place the cursor or mouse pointer in the location you want to edit.



- After horizontal line

A horizontal line is drawn in the relevant location.



4.1.5 Input instruction

Inputs normally open contact, normally closed contact, rising input contact, and falling input contact instructions.

Normally open contact	Contact normally stays in OFF status. When a certain input condition is ON, it also becomes ON.
Normally closed contact	Contact normally stays in ON status. When a certain input condition is satisfied, it also becomes OFF.
Rising input contact	Contact becomes ON when the previous status of the input contact changes from OFF to ON.
Falling input contact	Contact becomes ON when the previous status of the input contact changes from ON to OFF.

An input instruction cannot be located in the last column of the ladder line.

Hot key is as following table.

Input instruction	Hot key
Normally open contact	F3
Normally closed contact	F4
Rising input contact	Shift+F1
Falling input contact	Shift+F2

All input contacts are entered in the same way. The following is the example of input for normally open contact instruction in ladder editor.

- Before editing normally open contact

Select [Tool]-[Normally Open Contact] of menu or press F3 keyboard.



- Edit normally open contact

Place the cursor or mouse pointer in the location you want to edit.



- Device input

Press Enter keyboard or click with left mouse button, 'Device Input' dialog box appears as following.

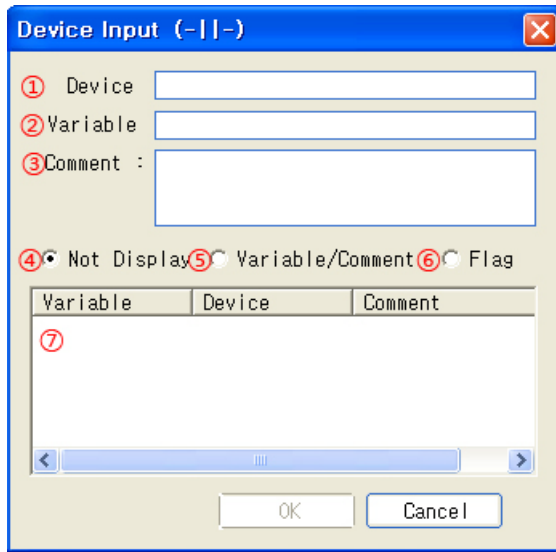

Device input	Description
① Device	Enter the device of normally open contact
② Variable	Enter the variable of the normally open contact
③ Comment	Enter the comment of the normally open contact
④ Not Display	Not display any contents in ⑦
⑤ Variable/Comment	Displays registered variable/comment in ⑦
⑥ Flag	Displays special device information in ⑦
⑦ Variable, Device, Comment	Displays the selected contents from ④ to ⑥

- After editing normally open contact

After entering the device and additional information, click 'OK' or press Enter keyboard. Normally open contact instruction with specified device is input at the relevant location.



4.1.6 Output instruction

Inputs output instruction, rising output contact, falling output contact, SET, RESET instructions.

Output instruction	Output contact is for output the operation result to device
Rising output contact	When the operation result is output to as device, output turns from OFF to ON with one scan and at the other scans it turns OFF status as output contact.
Falling output contact	When the operation result is output to as device, output turns from ON to OFF with one scan and at the other scans it turns OFF status.
SET	Once after SET by SET instruction, this contact maintains SET status even though input condition is OFF. (SET contact by RESET instruction turns OFF)
RESET	RESET instruction turns OFF to the specified contact when input condition is ON. (RESET contact turns ON by SET instruction.)

An output instruction can be located only in the last column of the ladder line.

Hot key is as following table.

Output instruction	Hot key
Output instruction	F9
Rising output contact	Shift+F5
Falling output contact	Shift+F6
SET	Shift+F3
RESET	Shift+F4

The following is the example of input for output instructions.

- Before editing output contact

Select [Tool]-[Output Instruction] of menu or press F9 keyboard.



- Edit output contact

Place the cursor or mouse pointer in the location you want to edit.



- Device input

Press Enter keyboard or click with left mouse button, 'Device Input' dialog box appears as following.

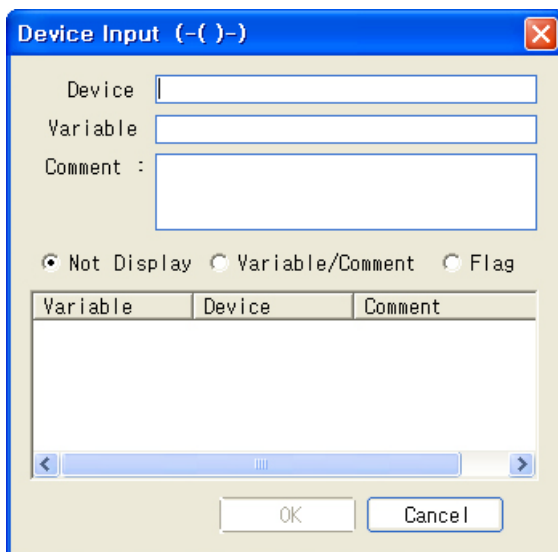

Device input	Description
①Device	Enter the device of output contact
②Variable	Enter the variable of output contact
③Comment	Enter the comment of output contact
④Not Display	Not display any contents in ⑦
⑤Variable/Comment	Displays registered variable/comment in ⑦
⑥Flag	Displays special device information in ⑦
⑦Variable, Device, Comment	Displays the selected contents from ④ to ⑥

- After editing output contact

After entering the device and additional information, click 'OK' or press Enter keyboard. Output contact instruction with specified device is input at the relevant location.



For further details of each instruction, refer to "LP series instruction manual". All output contacts are entered in the same way.

4.1.7 Application instructions

This menu is used to enter application instructions.

Select [Tool]-[Application Instructions] of menu or press F10 keyboard, 'Edit Ladder(Application Instructions)' dialog box appears.

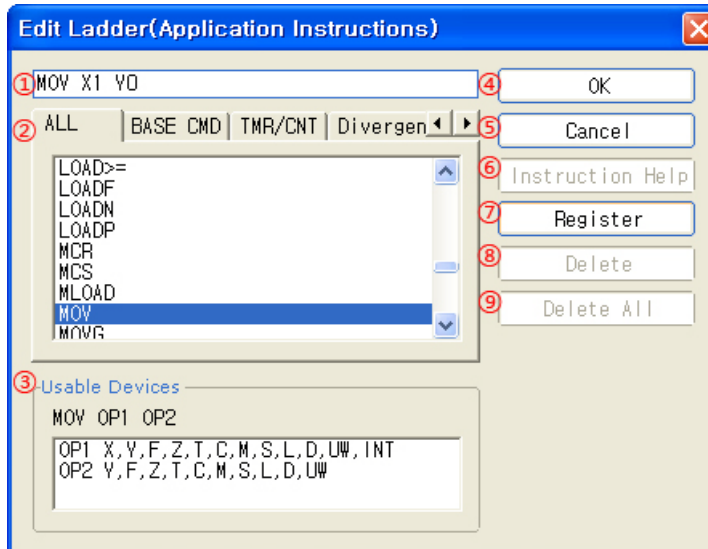

Application instruction	Description
① Application instruction	Enter application instruction directly.
② Application instruction	Displays available instructions to use for each tab. Double-click the instruction in ② and the selected instruction is input in ①.
③ Usable Devices	Displays usable devices of operand by the selected instruction.
④ OK	Application instruction is applied to the ladder editor.
⑤ Cancel	Cancel application instruction input.
⑥ Instruction Help	Shows help for the selected instruction.
⑦ Register	Registers selected instructions as frequently used instructions. Registered instructions appear under 'Register' tab in ②
⑧ Delete	Deletes instruction registered to the 'Register' tab.
⑨ Delete All	Deletes all instructions registered to the 'Register' tab.

Select the menu and click the cell between the input motion and the output motion in the ladder editor to input a ladder. Optional input of an application instruction is available.

When a ladder is input, it is always created next to an output motion.

- Before input application instruction



- Input application instruction



- Edit ladder (Application instruction) dialog box

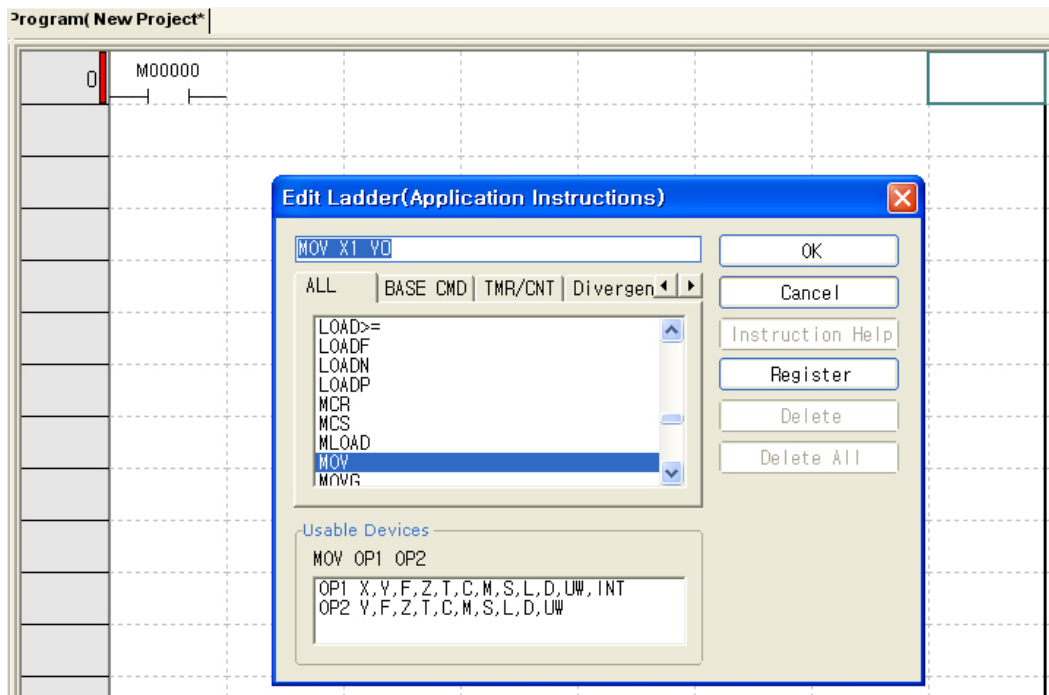

- After input application instruction

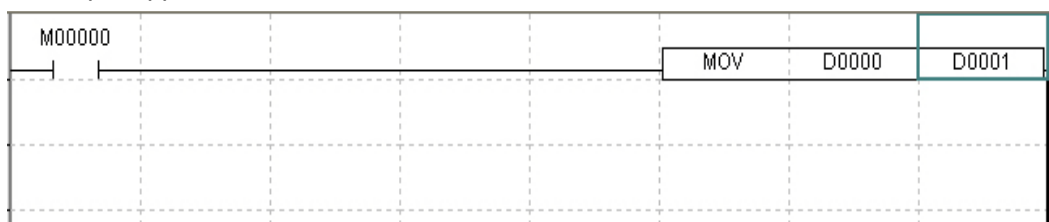

4.1.8 NOT instruction

This instruction is for reversing the input so far. Select [Tool]-[NOT Instruction] of menu or press Shift + F9 keyboard and the cursor displays with "*" sign. Click the desired cell to input the NOT instruction in ladder editor.

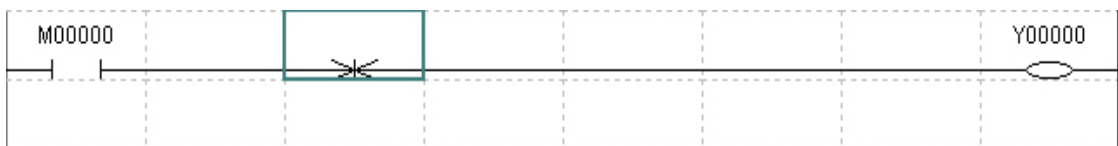

4.1.9 Register user defined function

Registers a rung as a user defined function in order to reuse a specified rung. Designate block of the area you want to register as a user defined function as below.

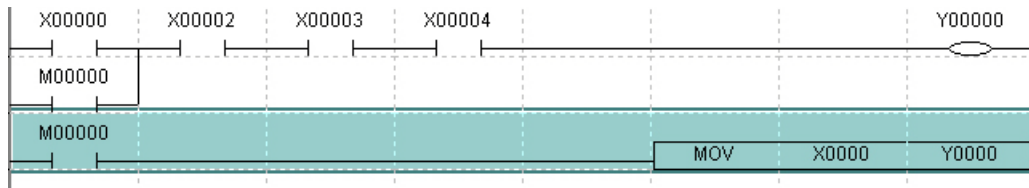

Select [Tool]-[Register User Defined Function] of menu or press Shift + F10 keyboard. Or click  in toolbar, 'Register User Defined Function' dialog box appears.

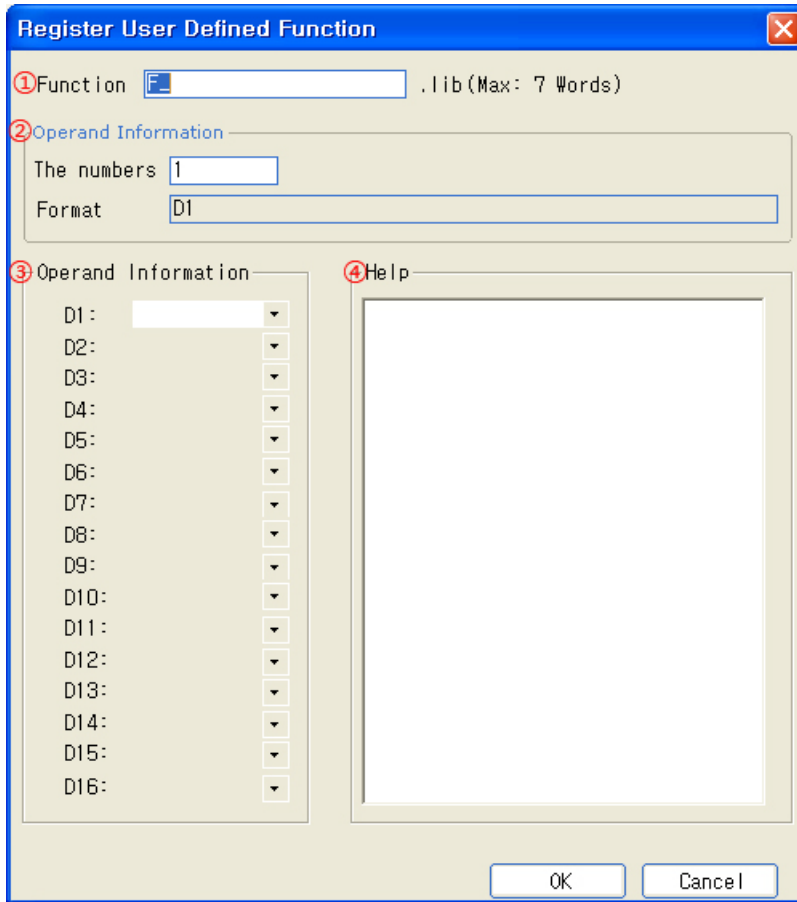

User defined function	Description
①Function	Enter the function name.
②Operand information	Specify the number of operands to use.
③Operand information	Specify a device of each operand as much as the specified number of operand. Devices assigned to the block appear in pull-down menu.
④Help	Enter the comment about the to be registered user defined function.

After completing above steps, click 'OK' and the user defined function is registered. The registered user defined function is stored in the \LIB folder as function name "function name.lib" file.

4.1.10 User defined function

Calls a user defined function registered to the user defined function library.

Select [Tool]-[User Defined Function] of menu or press Shift + F11 keyboard. Or click  in toolbar, 'Function List' dialog box appears.

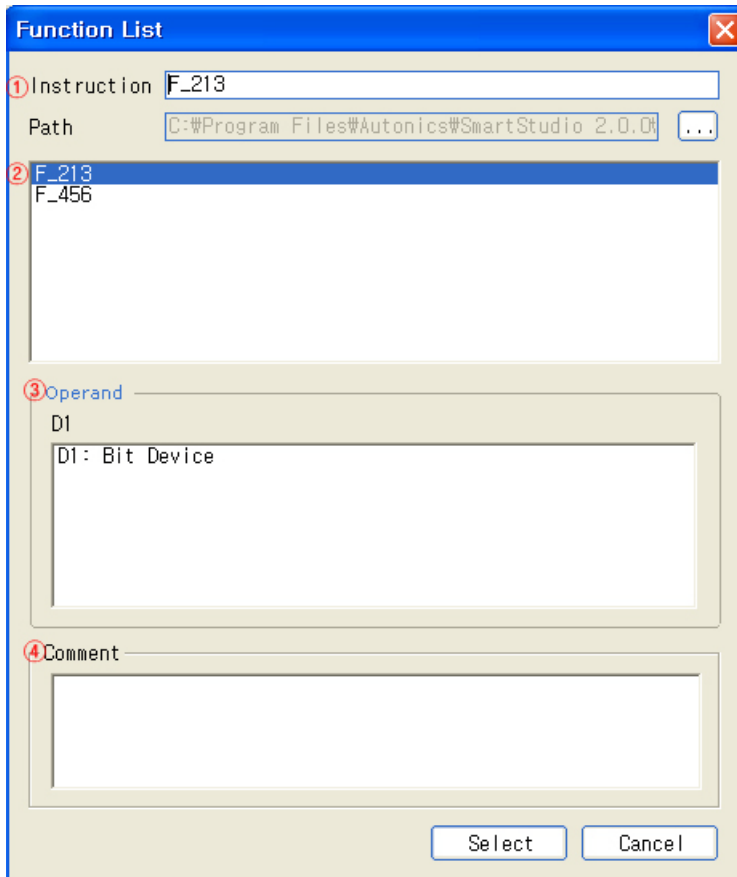

Function list	Description
① Instruction	Shows the selected user defined function.
② User defined function list	Shows a list of user defined functions stored in the specified folder at path.
③ Operand	Shows the device for the selected user defined function.
④ Comment	Shows description assigned to the selected user defined function.

After completing above steps, click 'Select' and the user defined function is applied in ladder editor.

Click 'Cancel' and 'Function List' dialog box closes regardless the contents entered.



Ex.

User defined function call is shown in the “FCALL+instruction+operand” format. The internal routine of the user defined function is added to the outside of the last END instruction, as shown in the green box in the image below.

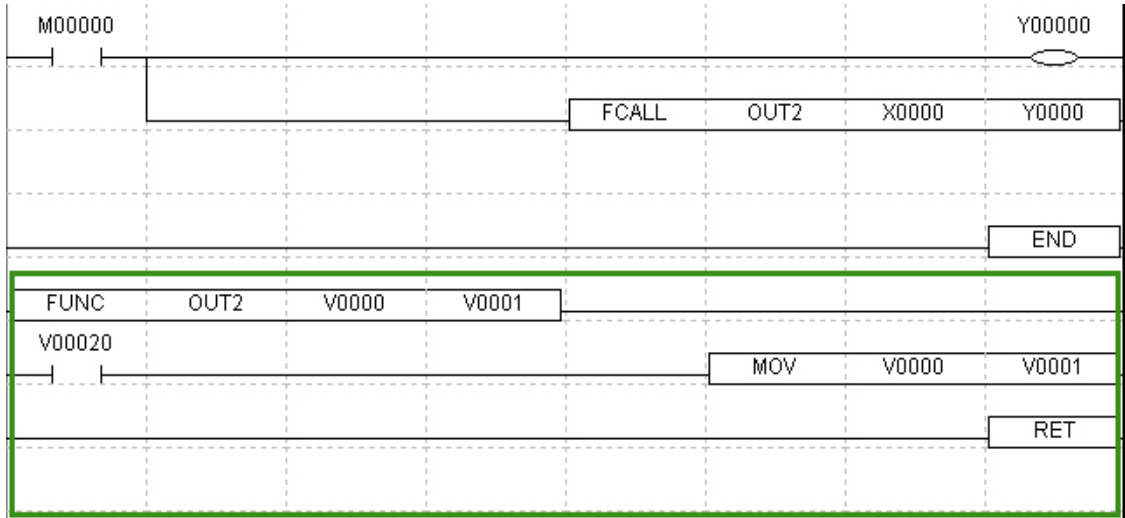

4.2 Program checking

4.2.1 Program optimization

Program optimization has two functions; connect ladder line in ladder editor, and clear NOP in ladder/mnemonic editor.

When executing program optimization in ladder editor, 'Program Optimization' dialog box appears and you can select 'Connect Ladder Line' or 'Clear NOP' function.

In mnemonic editor, there is only 'Clear NOP' function, 'Program Optimization' dialog box does not appear and it executes 'Clear NOP' function directly.

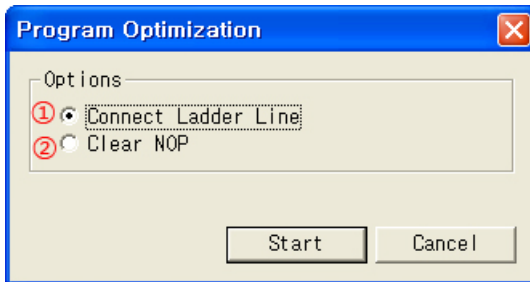

Program optimization	Description
① Connect ladder line	This feature forces connection of input lines of the open (not connected) ladder. This function does not guarantee validity of the ladder.
② Clear NOP	Mnemonic program can delete all NOP instructions. There is no change in the ladder shape.



Ex.

- Before connecting ladder line

Input contact and output contact in the second line are not connected together.

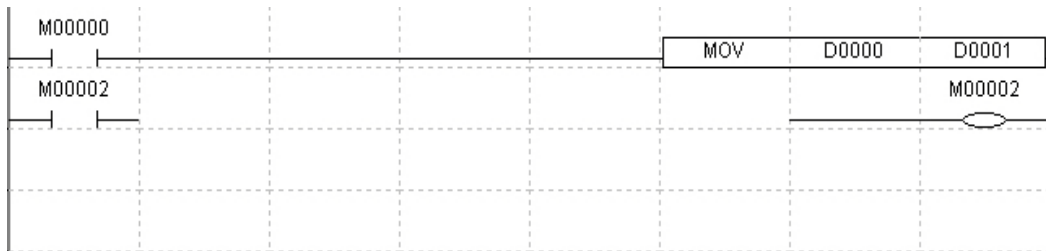

- Connect ladder line

Select [Tool]-[Program Checking]-[Program Optimization] of menu, 'Program Optimization' dialog box appears. This dialog box appears only in ladder editor. You can select 'Connect Ladder Line' or 'Clear NOP' functions. In this example, select 'Connect Ladder Line'.

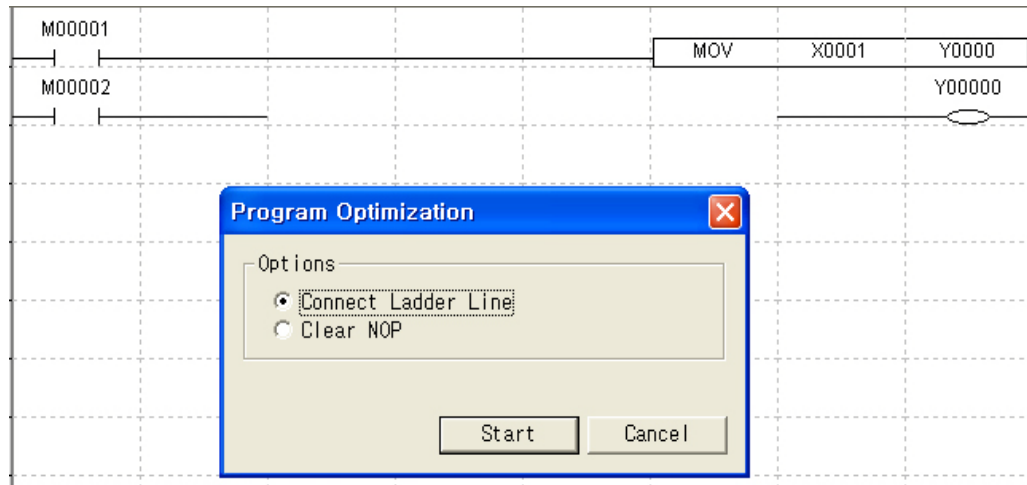

- After connecting ladder line

You can see the input contact and output contact are now connected.

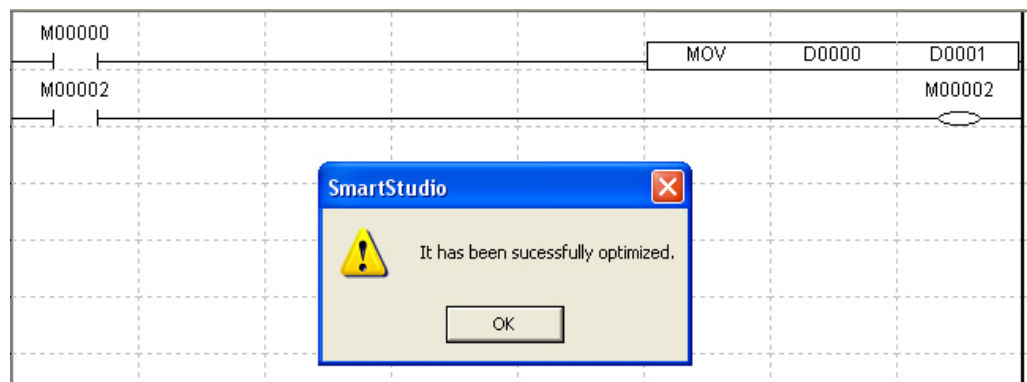

Ex.

- Before clearing NOP

Clear NOP is able to check in mnemonic editor.

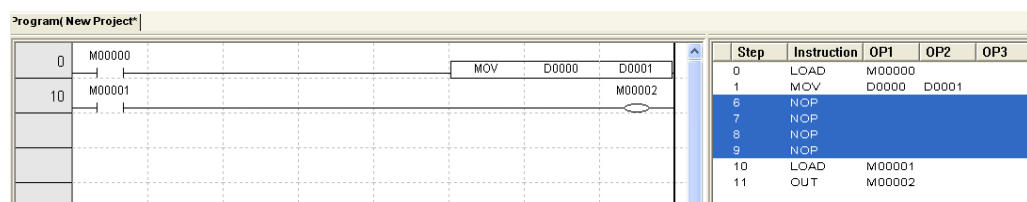

- Clear NOP

With activated ladder editor, select [Tool]-[Program Checking]-[Program Optimization] of menu and 'Program Optimization' dialog box appears. Select 'Clear NOP'. With only activated mnemonic editor, select [Tool]- [Program Checking]-[Program Optimization] of menu and 'Program Optimization' dialog box does not appear. It clears "NOP" instructions.

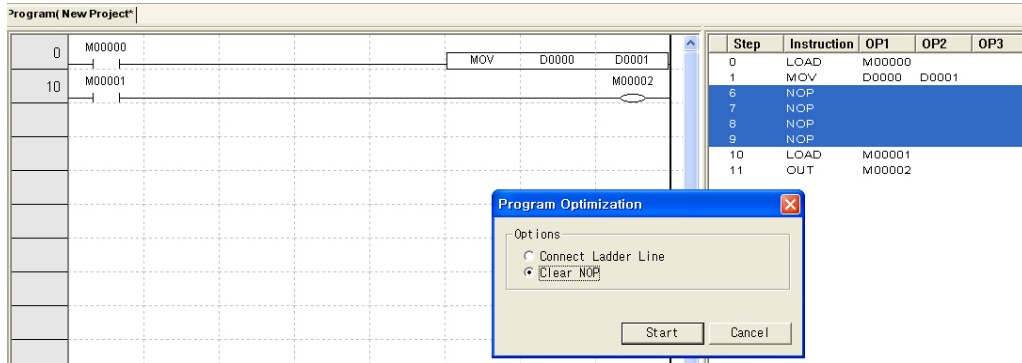

- After clearing NOP

You can see, in the mnemonic editor on right side, that previous NOP instructions are deleted.

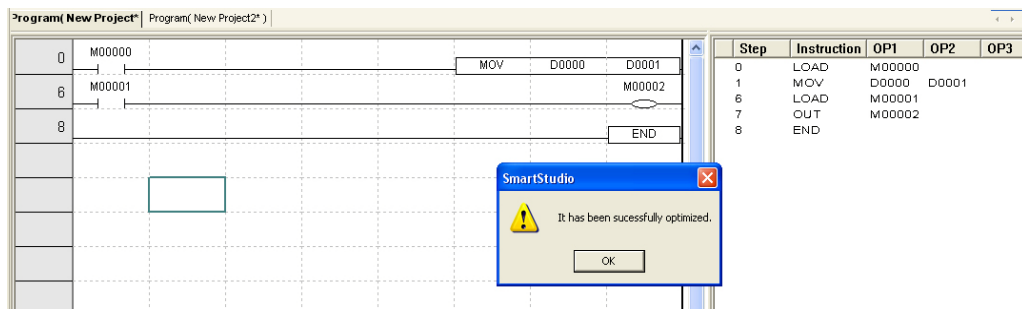

4.2.2 Program checking and options

This function checks to see whether there are program errors or not. Select [Tool]-[Program Checking]-[Program Checking Options] of menu and 'Checking Program Options' dialog box appears.

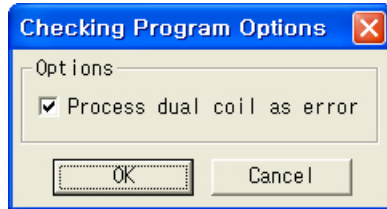

When checking 'Process dual coil as error', dual coil is processed as error and download is not available. When non-checking this, it displays warning message for dual coil and download is available.

Regardless option checking, click 'OK' and it checks the followings.

- Check dual coil
- Check program errors
- Check program capacity
- Others



Ex.

Program checking result is output in message box as followings.

- Example of without errors
"There is no error detected." message appears.

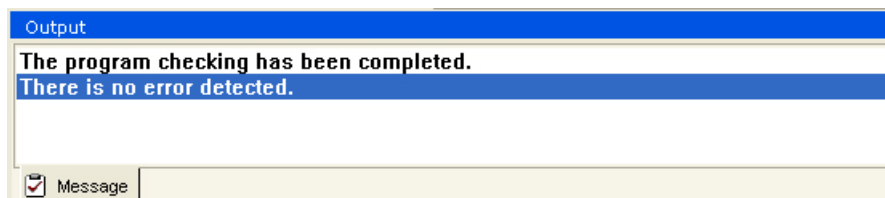

- Example of errors
Lines and steps with errors are written in the message box.

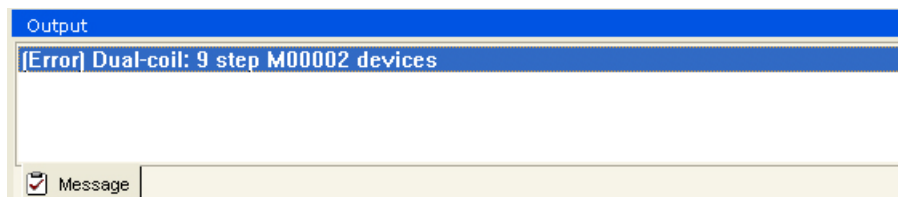

5 View

5.1 Ladder/Mnemonic

Whenever this menu is selected and the program editor window is ladder, it converts the to mnemonic and vice versa.

- Ladder

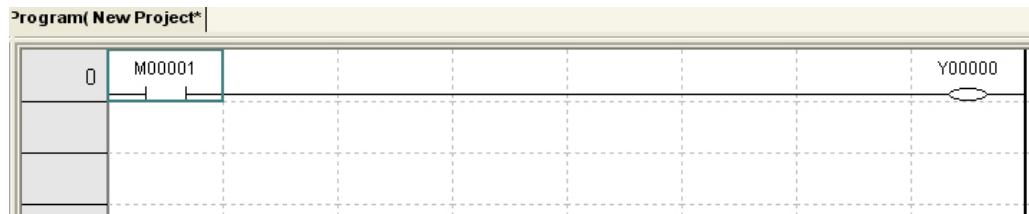

- Mnemonic

Step	Instruction	OP1	OP2	OP3	OP4	OP5	OP6	OP7	OP8
0	LOAD	M00001							
1	OUT	Y00000							

5.2 Device name

Displays the devices used in the program by name.

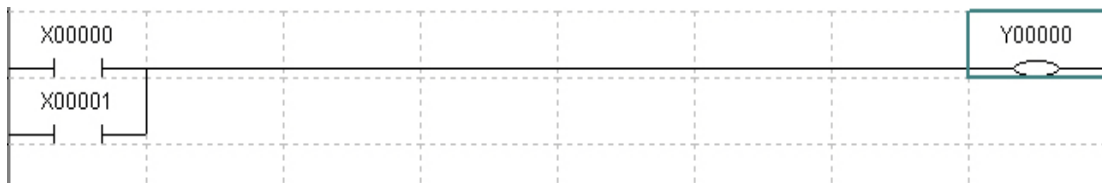

5.3 Variable name

Displays variable names of the devices used in the program.

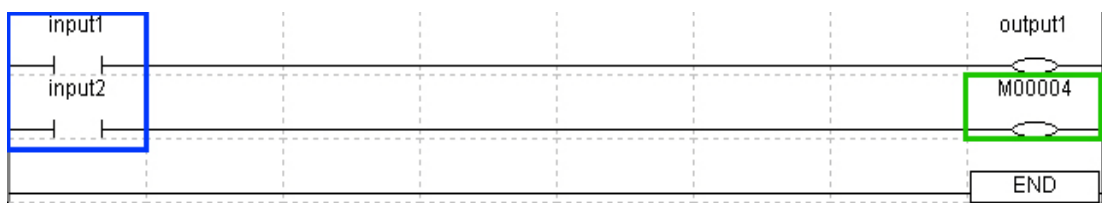

Devices with a registered variable name are displayed by the variable name (within blue box in the above image). Devices without a registered variable name are displayed by device name (within a green box as in the above image).

5.4 Device name & Variable name

Displays devices in both device name and variable name.

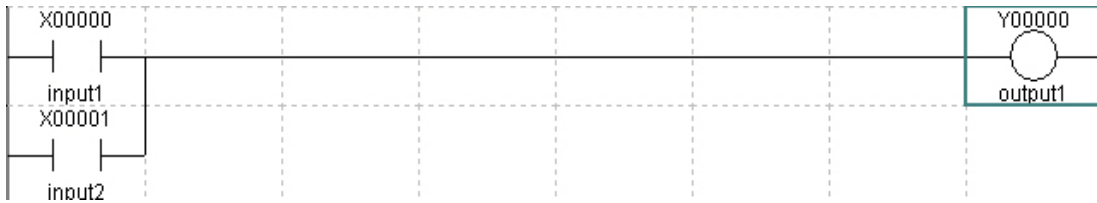

5.5 Device name & Comment

Displays the device used in the program along with its description.

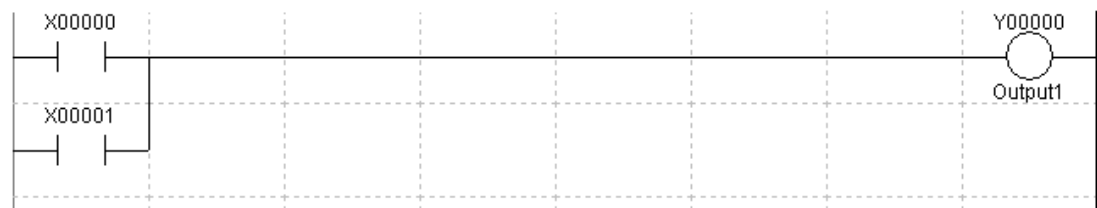

Device without a registered description is displayed only by device name such as the input contact in the above image.

5.6 Used devices

Used devices displays the present usage state of the devices.

Select [View]-[Used Devices] of menu and 'Status of Used Devices' dialog box appears. You can check the information of devices to select a desired device. When using a device more than one time, used device displays the number of the using devices.

(1) 'Status of Used Devices' dialog box layout

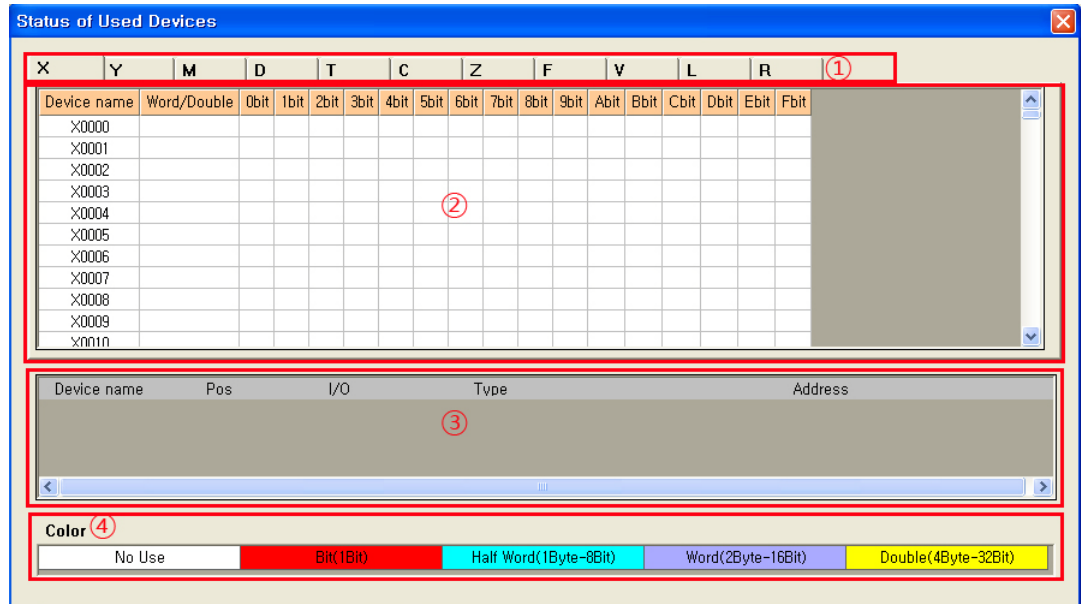

Status of used devices	Description
① Device tab bar	Device tab for the using device
② Present status list	Displays whether the device is using or not with color. <ul style="list-style-type: none"> Word/double: Displays using device except bit data OtoF bit: display bit using devices The number is for the used times of appropriate device.
③ Detailed using list	Displays detailed information of the device by clicking present state list
④ Color	Classified devices by color

(2) Present status list

Device type	Description
Bit	Device in UB unit
Byte	Device in successive 8 UB unit
Word	Device in UW unit
Double word	Device in successive 2 UW unit

Sign	Description
←	Device direction with each bit device when using device over 1 byte

(3) Detailed using list

Item	Description
Device name	Displays the using device
Pos	Coordinates of devices located in ladder cell
I/O	Displays the state (input/output) of the device
Type	Device type (Bit, Byte, Word, DWord)
Address	Used address of LP system

(4) Color

Color	Description
No Use	Not using device
Bit(1Bit)	Displays using bit type device
Half Word(1Byte-8Bit)	Displays using 1byte (8bit) type device
Word(2Byte-16Bit)	Displays using 2byte (16bit) type device
Double(4Byte-32Bit)	Displays using 4byte (32bit) type device

(5) To display a device used more than one time

When a device is used at more than one device, present state list displays the number of the using devices as following. Click the number, and detailed using list displays the device list information.

The screenshot shows the 'Status of Used Devices' window. The main grid has columns for device names (X, Y, M, D, T, C, Z, F, V, L, R) and rows for device types (0bit, 1bit, 2bit, 3bit, 4bit, 5bit, 6bit, 7bit, 8bit, 9bit, Abit, Bbit, Cbit, Dbit, Ebit, Fbit). A red box highlights the '0bit' column for device 'M0000', which contains the number '2'. A red line connects this cell to the detailed list below.

Device name	Pos	I/O	Type	Address
M00000	(6,0)		BIT DEVICE	M Address: 00, UB200000
M00000	(7,0)		BIT DEVICE	M Address: 00, UB200000

At the bottom, there is a 'Color' legend with five categories: No Use (white), Bit(1Bit) (red), Half Word(1Byte-8Bit) (cyan), Word(2Byte-16Bit) (purple), and Double(4Byte-32Bit) (yellow).

(6) To find device on ladder by detailed using list

You can find position information of device at detailed using list at the device on ladder.



Ex.

To find the device positioned position (6, 7)

Status of Used Devices

X	Y	M	D	T	C	Z	F	V	L	R							
Device name	Word/Double	0bit	1bit	2bit	3bit	4bit	5bit	6bit	7bit	8bit	9bit	Abit	Bbit	Cbit	Dbit	Ebit	Fbit
M0048																	
M0049																	
M0050	13	←	←	←	←	←	←	←	←	←	←	←	←	←	←	←	←
M0051																	
M0052																	
M0053																	
M0054																	
M0055																	
M0056																	
M0057																	

Device name	Pos	I/O	Type	Address
M0050	(6,7)		WORD DEVICE	M Address: 50, UW20050
M0050	(7,7)		WORD DEVICE	M Address: 50, UW20050
M0050	(11,6)		WORD DEVICE	M Address: 50, UW20050

Color

No Use	(Bit)1Bit	(Half Word)1Byte-8Bit	(Word)2Byte-16Bit	(Double)4Byte-32Bit
--------	-----------	-----------------------	-------------------	---------------------

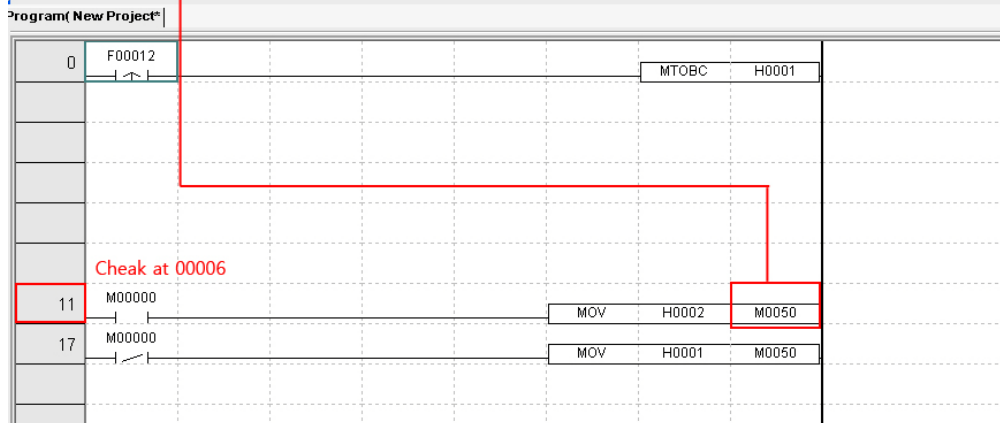

Position (x, y) of detailed using list is matched (line, column) of ladder. (The position of detailed using list starts from y, x(0, 0).)

Therefore, the device of above figure position (6, 7) is matched the device which is placed at 6th line (y) and 7th column of ladder.

5.7 Decimal/Hexadecimal view

Sets integers in the program or data values for monitoring as decimal number view or hexadecimal number view.

These two status are not applied at the same time.

(1) Decimal view

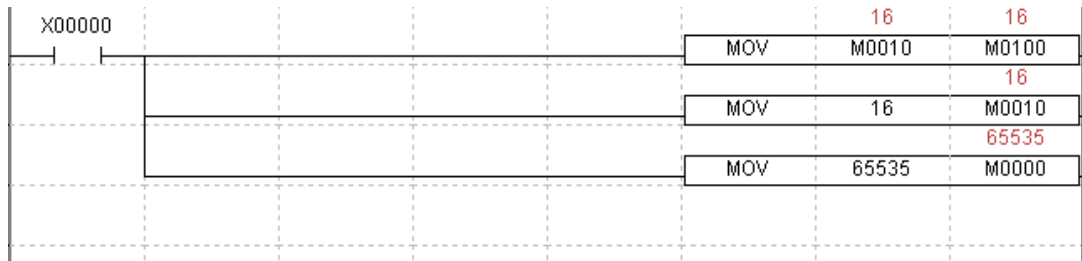

(2) Hexadecimal view

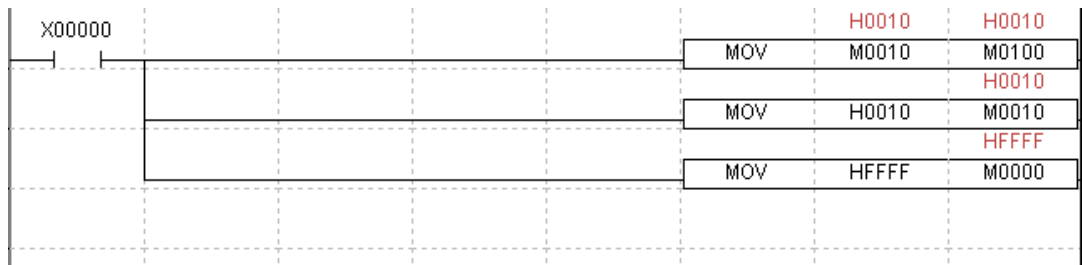

5.8 Signed/Unsigned view

Shows integers in the program or monitoring values as Signed or Unsigned.

These two status are not applied at the same time.

(1) Signed view

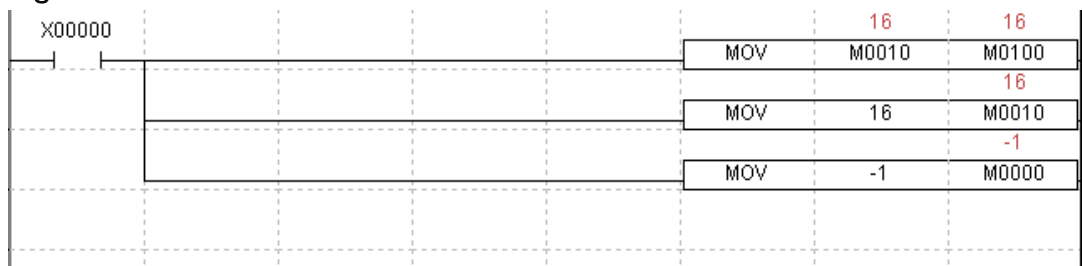

When you change to [Signed View], it is changed decimal view and signed view both.

(2) Unsigned view

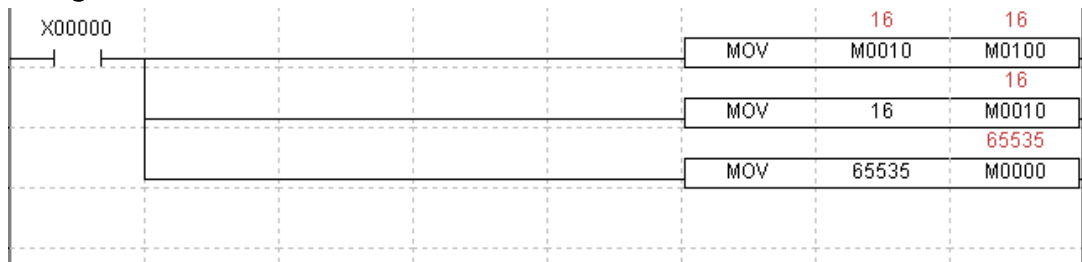

5.9 UW (GP device)/Device (LP device) view

Sets view mode of the device as either LP Device View or GP Device View.

(1) UW (GP device) view

It converts a LP device to a device that can be used in GP.

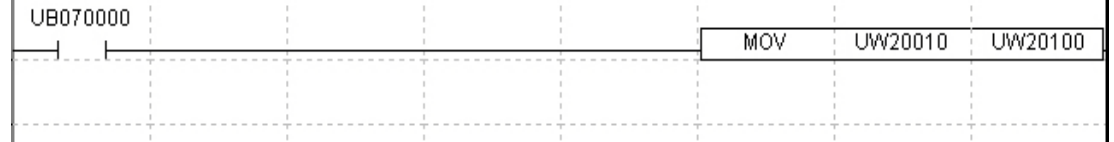

(2) Device (LP device) view

It shows actual device used in LP.

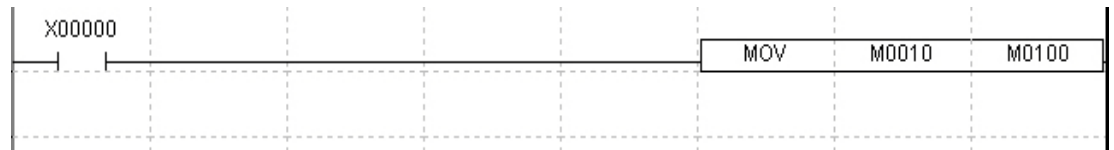

5.10 Zoom in/out

Increases or decreases the ladder editor screen.

The screen zoom range is from max 175% to min 25% increasing by steps of 25%. The following shows ladder screens adjusted to 25% and 175% respectively.

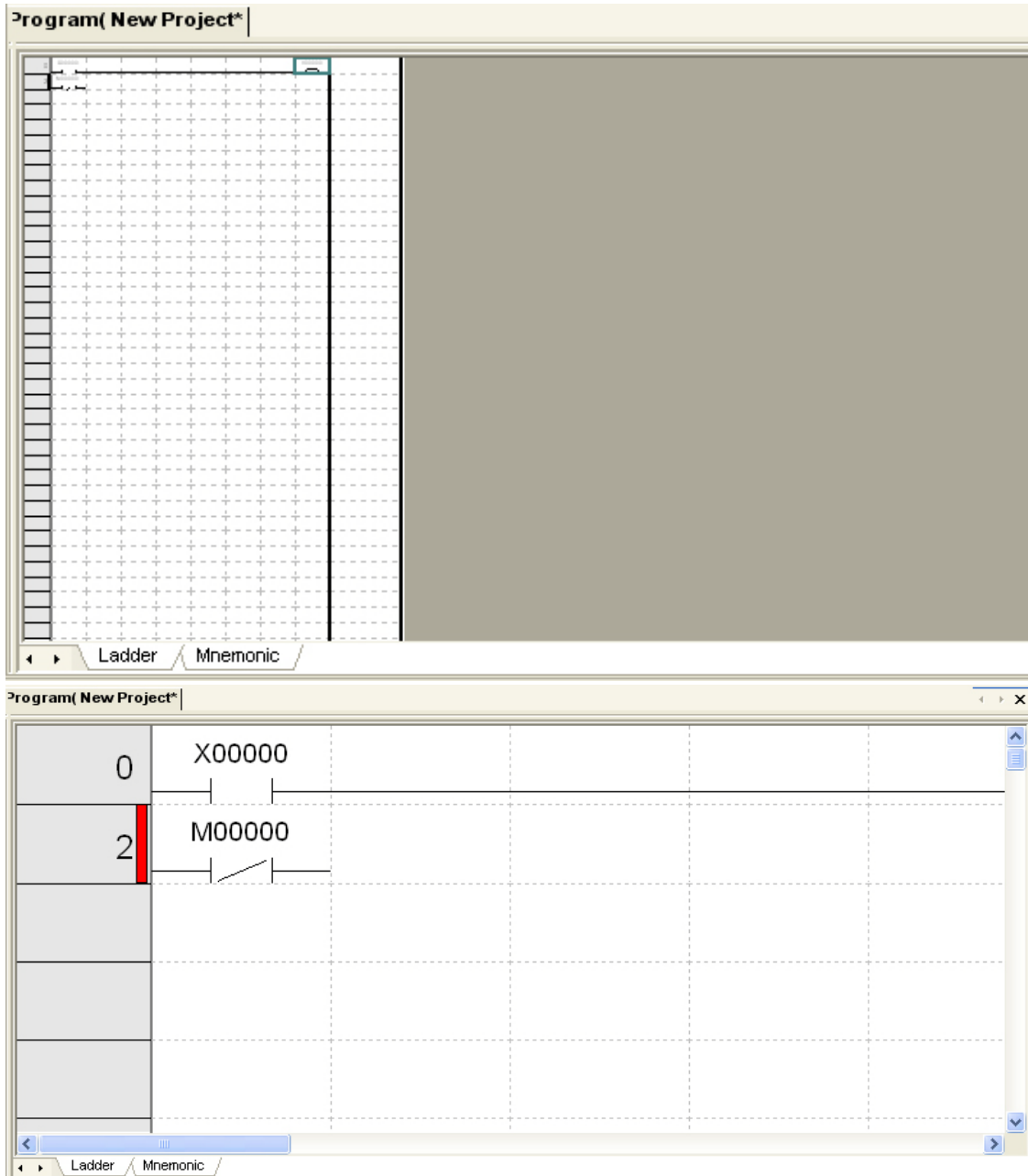

5.11 Font settings

Sets text font face used in the program.

Font size setting is interconnected with screen zoom.

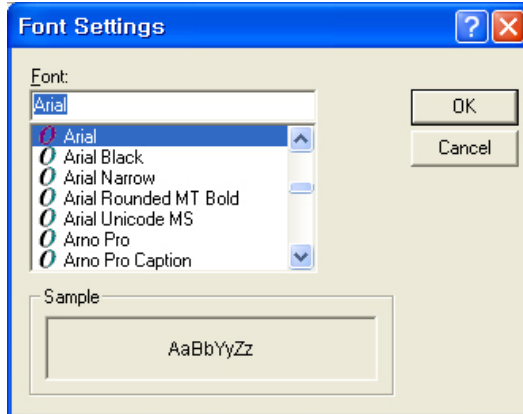

5.12 Color settings

Changes the color of the Ladder Editor. Select an item in the list box to change color. The color of the selected item is displayed in the preview of 'Color Settings' dialog box. Click 'Apply' and ladder editor color is changed.

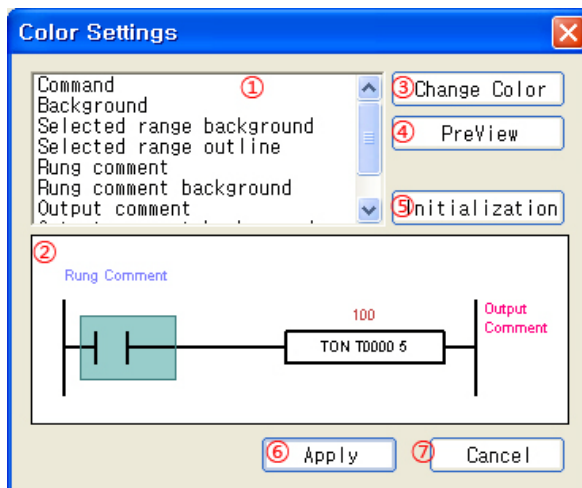

Color settings	description
①Item	List of items to be changed color
②Preview	Previews the changed color
③Change Color	Changes the color of selected items in the list
④Preview	Shows the new color in the ladder editor
⑤Initialization	Ignores user changed color and initializes the color of the ladder editor
⑥Apply	Applies the new color and closes 'Color Settings' dialog box.
⑦Cancel	Cancel the new color, applies the previous color and closes 'Color Settings' dialog box.

5.13 Toolbar

Selects whether to display the toolbar or not.

Toolbar	Icon
Project tool	
Ladder tool	
Online tool	
Edit tool	
View tool	
Debug tool	
External program connection	

5.14 Workspace

Selects whether to display the work space or not.

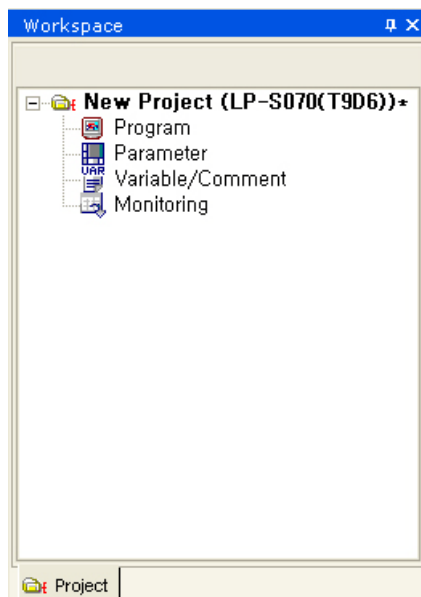

5.15 Message box

Selects whether to display output message window or not.

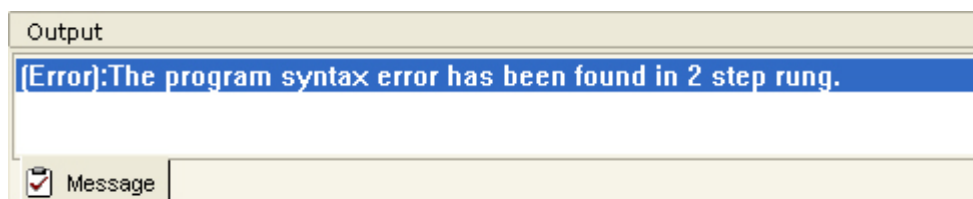

6 Online

6.1 Connecting

Attempts to connect to LP and SmartStudio with predefined communication option (communication port, communication speed; BPS). Whether the connection succeeds or fails is notified through the message window.

You can check the connecting status as following toolbar.

- Disconnection status



- Attempting to connect status



- Connected status



6.2 Disconnecting

Disconnects between SmartStudio and LP.

After disconnected, online toolbar changes as above and online menus are disabled.

- Before disconnecting



- After disconnecting



6.3 Download

Downloads active project programs and parameters to the LP. Download is only available when status between SmartStudio and LP is "connected" and there is an active project.

You can choose programs and parameters to download.

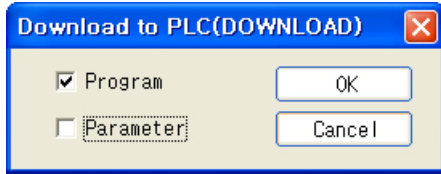

Note

Please check the followings before downloading.

1st Make sure the PLC type in SmartStudio and the system's PLC type match before download. The program does not check PLC type when connecting.

2nd Automatically performs program error checking.

If there is error, after checking, the following message appears.

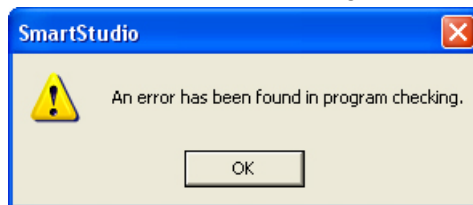

If there is no error, the following message appears and download processes.

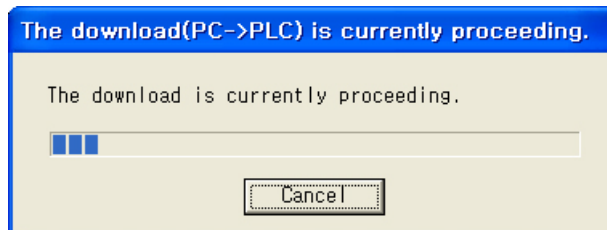

6.4 Upload

This feature brings programs and parameters from PLC to PC in SmartStudio. When connecting starts SmartStudio and LP, select [Online]-[Upload] of menu and the following dialog box appears.

You can choose programs and parameters to upload.

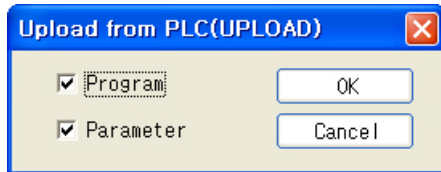

If the uploaded project is the same project you are currently working on in SmartStudio, the following dialog box appears. When the upload is completed. You can choose whether to continue working on the current project to click 'Yes', or open and work on the newly uploaded project to click 'No'.

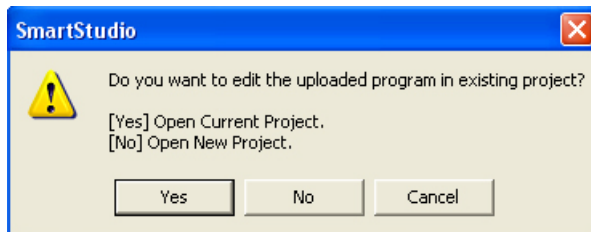

6.5 Change mode

Changes operation mode of the LP.

There are 5 operation modes of the LP: RUN, STOP, PAUSE, DEBUG, H/W STOP.

- If the LP system mode is set to RUN mode,
It can be changed to STOP or PAUSE mode. If you are in the middle of monitoring, you can change the mode to DEBUG mode.
- If the LP system mode is set to STOP mode,
It can be changed to RUN mode. If you are in the middle of monitoring, you can change the mode to DEBUG mode.
- If the LP system mode is set to PAUSE mode,
It can be changed to RUN or STOP. If you are in the middle of monitoring, you can change the mode to DEBUG mode.
- If the LP system mode is set to DEBUG mode,
It can be changed to RUN mode.
- If the LP system mode is set to H/W STOP mode,
Mode control in SmartStudio is not available. H/W STOP is a mode where LP system switch is set to STOP.

Mode control in SmartStudio is not available. H/W STOP is a mode where LP system switch is set to STOP.

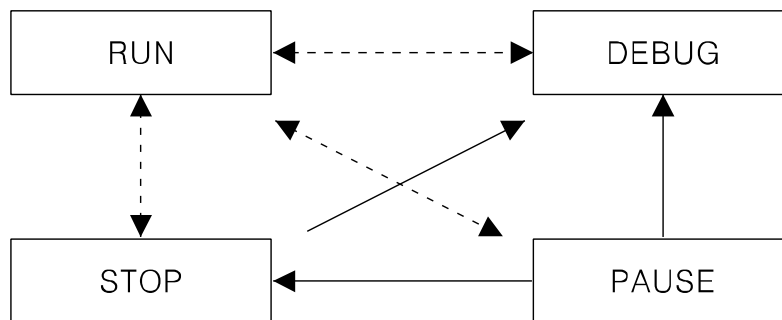

- RUN: Executes the program downloaded to LP.
- STOP: Stops running program. This mode is enabled when the system mode is RUN.
- PAUSE: Temporarily stops the running program. When this mode is off, the program continues to run from the point of pause.
- DEBUG: Stops the program and enables debug menus.



Note

Operation mode

- RUN mode
RUN mode repeats the following processes in order. Reads external contact status and saves it in internal memory; executes user program operations, such as step order or branch instruction and interrupt, to the END line; sends output device memory values as external output signals. This sequence is repeated.
- STOP mode
STOP mode stops execution of user program, initializes internal memory data (latch area, some special devices are excluded) as well as turns all external output signals off to block external signals from the program.

- PAUSE mode
Pause mode stops only the execution of user program, and keeps internal memories and external output signals.
- DEBUG mode
DEBUG mode stops execution of user program at 0 step, initializes internal memory data (latch area, some special devices are excluded) as well as turns all external output signals off. It is also in a wait state for executing debug instructions.

6.6 Start monitoring/Stop monitoring

Monitors to reflect system's operation status to the editor if programs of the active project and the system are same to applied it on the program.

The operation mode can be changed to DEBUG mode while monitoring. You cannot stop monitoring in DEBUG mode.

If programs of the active project and the system are not the same, monitored values may be inaccurate.

Bits or word device values are displayed in program editor while monitoring, as in the following image.

- Before monitoring

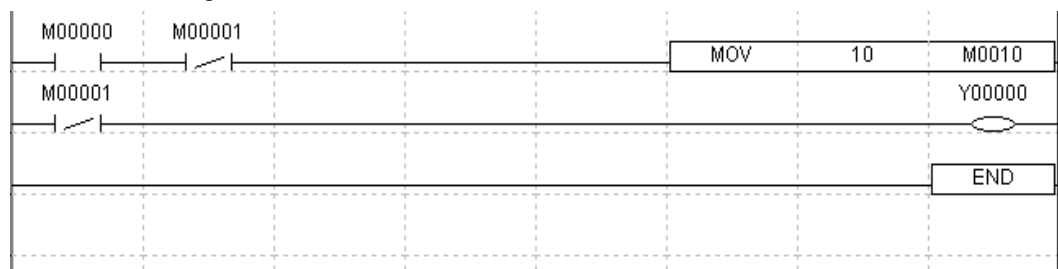

- After monitoring

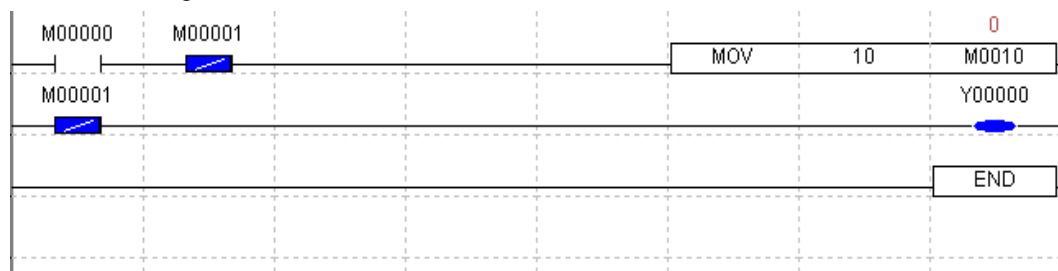

6.7 Read information

Reads and shows the system information of the connected LP system.

Select [Online]-[Read Information] of menu and 'Read PLC information' dialog box appears and reads the following items of PLC.

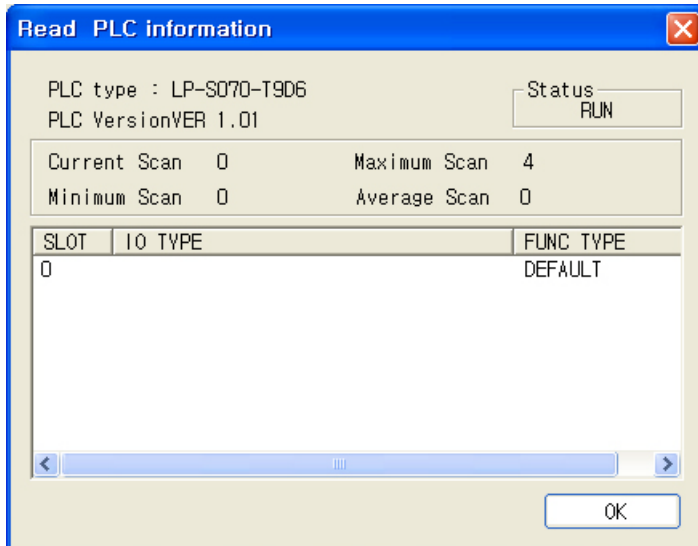

Item	PLC TYPE→SERIES + MODEL Ex)LP-S070 T9D6
	PLC version: Firmware version
	Status: PLC mode (RUN, STOP, PAUSE, DEBUG) Hardware switch status (RUN, STOP)
	Current scan time
	Maximum scan time
	Minimum scan time
	Average scan time
	Slot information

6.8 Change password

Sets and edits communication password on LP system.

If the password is set already, it checks the password for upload.

Select [Online]-[Change Password] and 'Change PLC Password' dialog box appears.

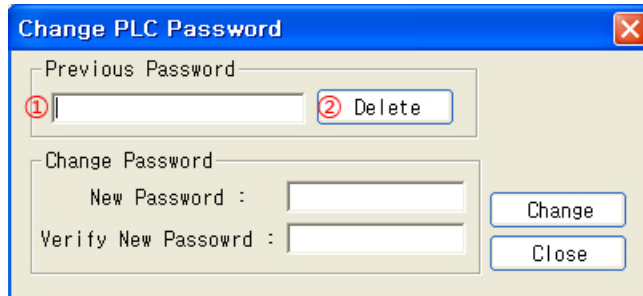

(1) Delete password

If the password is set, the coded password is shown in ① 'Previous Password'.

Delete the coded password in ① and enter the previous password and click ② 'Delete'. It deletes the preset password in the LP system.

(2) Change password

- ① When there is set password,
 - Enter the previous password in ①
 - Input new password in 'New Password' and 'Verify New Password'.
 - Click 'Change'.
- ② When the password is deleted,
 - Maintains ① with blank.
 - Input new password in 'New Password' and 'Verify New Password'.
 - Click 'Change'.

(3) Lost password

If you lost your password, notify Autonics for the coded password in SmartStudio.

6.9 Verify

Compares program and parameter settings of the editor with those of the system, and displays the result. Verify checking is for program and parameter.

This function is able to execute regardless LP operation modes. If you did not specify the range of steps to compare, it compares the whole steps.

Select [Online]-[Verify] of menu, and 'Verification of Program/Parameter configuration' dialog box appears.

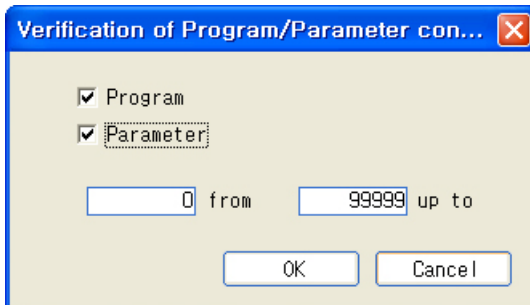

The following dialog box displays the process in which the program and parameter information is being read and compared.

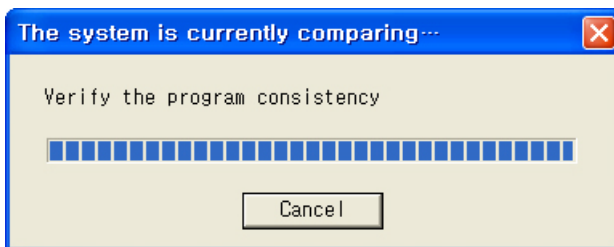

When the comparison is complete, the following dialog box appears for its status.

[Consistent]

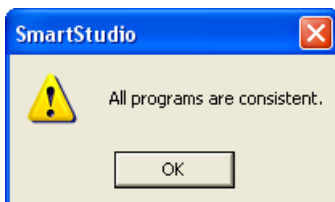

[Inconsistent]

When parameter is inconsistent,



When program area is inconsistent,

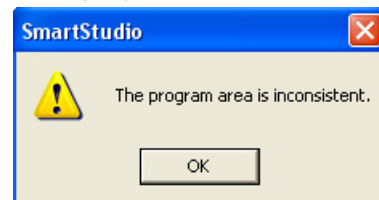

6.10 Change present value

This function forces setting values for internal devices (except input/output devices) while monitoring.

If a device value is set by changing present value, it is un-set when you change the mode of the LP system.

Select [Online]-[Change Preset Value] of menu, 'Change Present value' dialog box appears and you can change the present value.

Changing present value is executed regardless of LP operation mode.

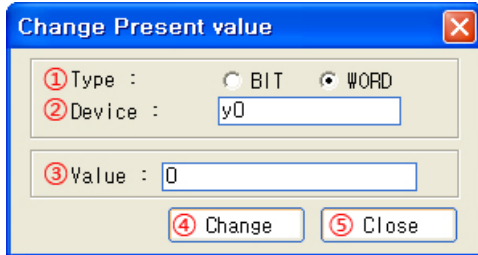

Change present value	Description
①Type	Select the device type to be changed
②Device	Enter the device to change present value
③Value	Enter the to be changed present value of the device
④Change	After entering ① to ③, click 'Change' and the entered present value is applied to the device.
⑤Close	Ignores input value and closes 'Change Present value' dialog box.

If you want to change the present value of a specific device in the program, move the cursor to the relevant device, click with right mouse button and pop-up menu appears. Select [Change Present Value] of pop-up menu and the device is designated automatically and the appropriated present value is selected.

6.11 System device

Monitors devices of the entire system.

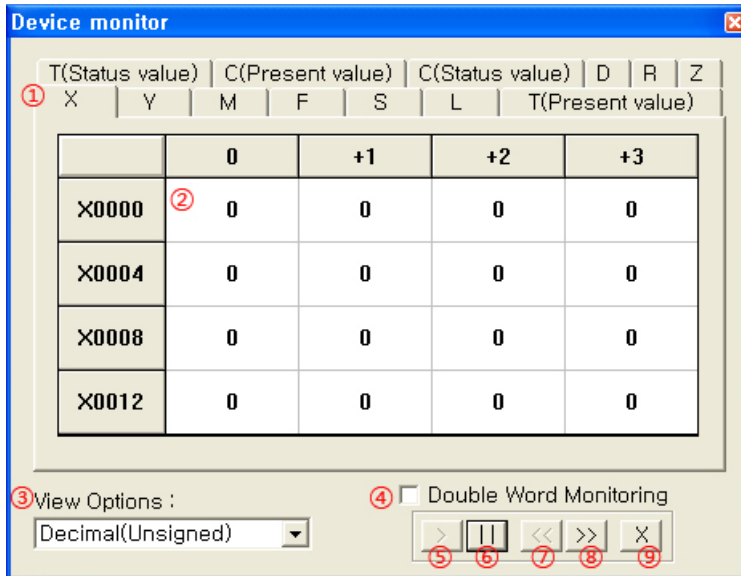

Device monitor	Description
① Device	Select the device of system to monitor
② Monitoring value	Displays monitoring value of the device.
③ View Options	Select view options for displaying monitoring value by pull-down menu. Decimal(Unsigned)/Hexadecimal/Binary/Decimal(Signed)
④ Double Word Monitoring	With non-checking this, it displays the value as word unit. Checking this, it displays the value as double word unit.
⑤ Start	Starts monitoring
⑥ Pause	Pauses monitoring
⑦ Move(decrease)	Moves(decrease) the device address.
⑧ Move(increase)	Moves(increase) the device address.
⑨ Exit	Finishes device monitoring.

6.12 Delete

6.12.1 Data

This function initializes system device. Delete data function is enabled only when LP operation mode is STOP. Select a device to delete and run the function to delete the device data.

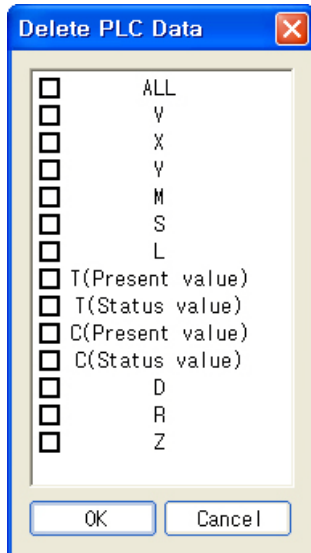

If you check 'ALL', entire system devices can be selected/deselected. Click 'OK' and it deletes (initializes) the selected devices.

6.12.2 Program/Parameter

Deletes program and parameter information stored in the LP system.

Delete program function is able to delete PLC program, line comment, rung comment, variable, LABEL, project, and password data.

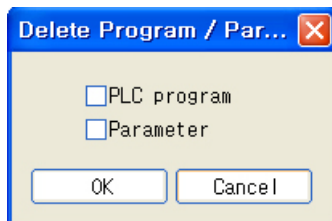

Default is checked both 'PLC program' and 'Parameter'. You can select each item to delete.

When deleting 'PLC program', password is also deleted.

6.13 Firmware download

Firmware file is different by LP model. It is able to read only same set LP type in SmartStudio. Firmware download menu is only supported in LP-S044 series.

- 1st Select [Online]-[Firmware Download] of menu and 'Firmware Download' dialog box appears.

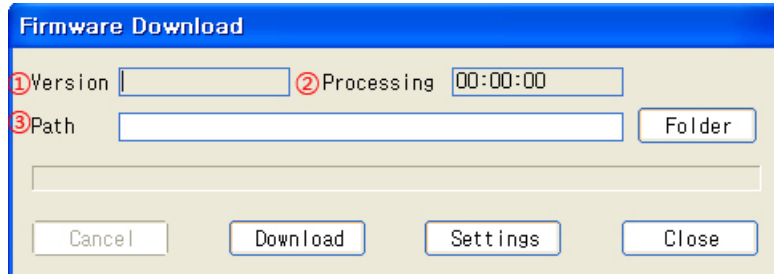

Firmware download	Description
①Version	Firmware version to download
②Processing	Process time to download
③Path	Designate file path to download

- 2nd Select the firmware file to be downloaded in LP and click 'Download' and 'System Information' dialog box appears to compare with the to be downloaded firmware and the current LP firmware.

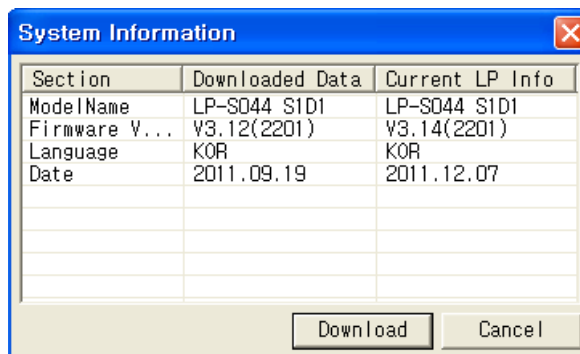

If the to be downloaded firm ware is order than the current LP firmware, the following message appears whether to download or not.

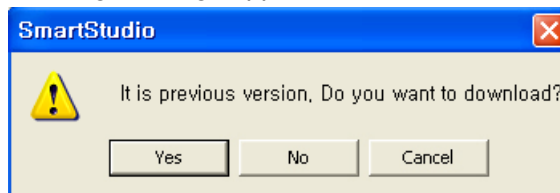

3rd 'Firmware Download' dialog box appears and it shows download processing.

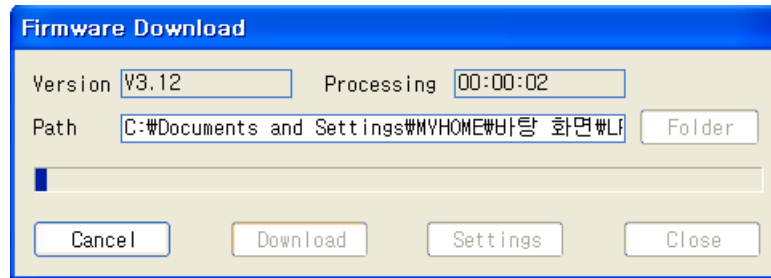

Note

In case that LP type is RS-232C A, RS-232C B port, RS-232C B port is available for firmware download. In case that LP type is RS-232C, RS-422 port, RS-232C port is available for firmware download.

LP-S070 model is not supported firmware upgrade by SmartStudio. To upgrade firmware of LP-S070, saves the firmware file to USB memory stick and put this in USB HOST port of LP-S070. Enter the system menu [Data]-[Firmware upgrade] of LP-S070. For further details, refer to "LP-S070 user manual".

6.14 Communication options

This function is enabled only when the system and SmartStudio are not connected. Designate communication options for communication with LP.

Select [Online]-[Communication Options] and 'Communication Options' dialog box appears.

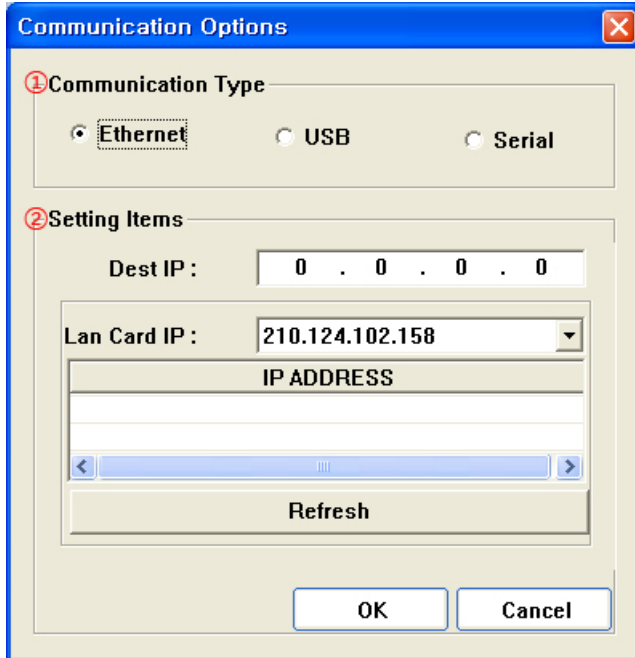

Options	Description
① Communication type	Communication type between LP and SmartStudio: Select Ethernet, USB, or Serial.
② Setting items	Communication setting items appears by communication type.



Note

Communication type by LP model

Type \ Model	LP-S044	LP-S070
Serial	●	●
Ethernet	-	●
USB	-	●

6.14.1 Serial communication

Connects LP and SmartStudio by 'Com' port

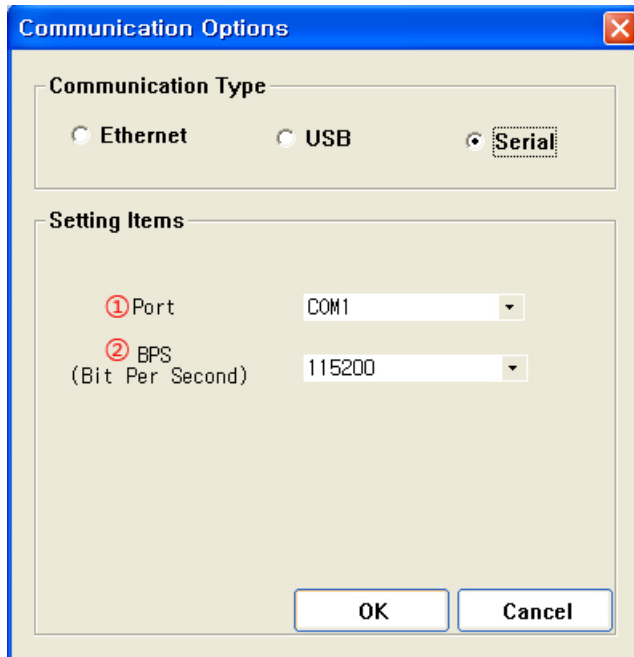

Serial	Description
①Port	Select serial communication port to communicate with LP by pull-down menu.(COM1 to COM32)
②BPS	Select serial communication speed (BPS) to communicate with LP by pull-down menu. (110 bps to 115200 bps)

Except port and bps, the other items are fixed.

Item	Fixed value
Data	8 bit
Stop bit	1 bit
Parity	Even
Flow control	XON / XOFF

6.14.2 Ethernet communication

Connects LP and SmartStudio by 'Ethernet'.

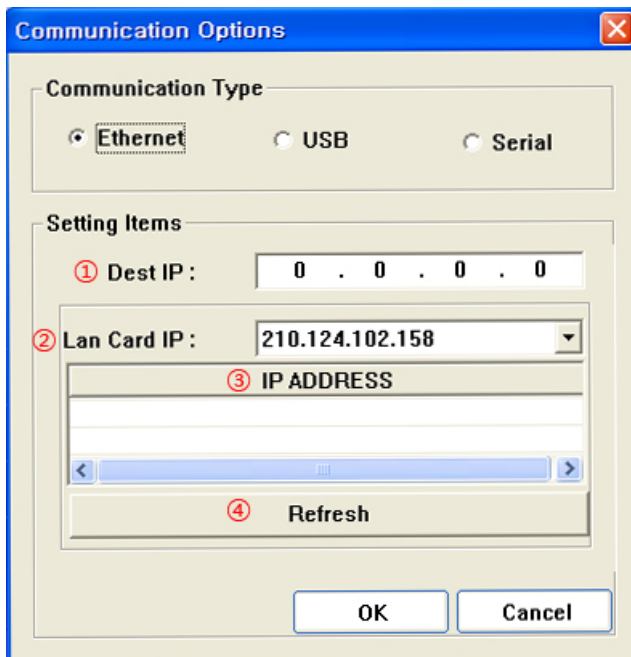

Ethernet	Description
① Dest IP	Register IP address to actual use
② Lan Card IP	Select IP address of PC LAN card to communicate with LP by pull-down menu
③ IP ADDRESS list	Displays IP ADDRESS list of connected LP
④ Refresh	Refreshes IP ADDRESS list.

It is able to download PLC program only when registered on destination IP. Destination IP defaulted to 0.0.0.0 is able to enter destination IP directly or select destination IP from IP ADDRESS list by double clicking.

6.14.3 USB communication

Connects LP and SmartStudio by 'USB'.
It is not required additional communication setting.

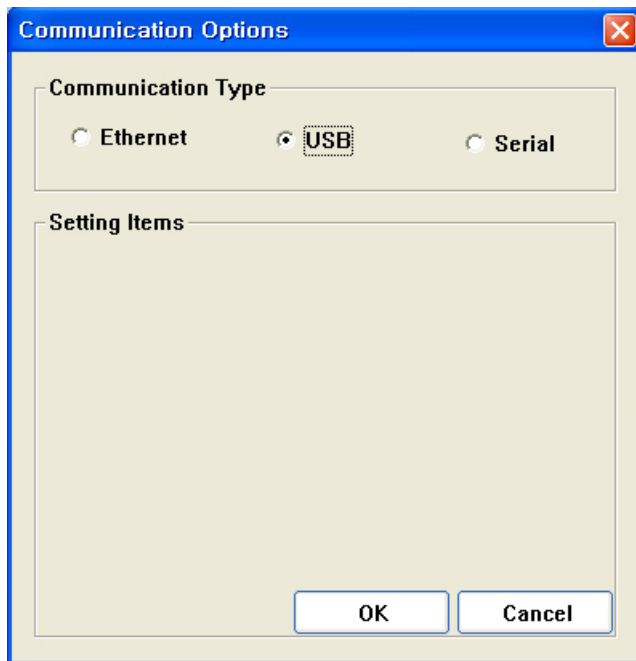

7 Debug

7.1 Run

Switches to debug run mode.

Use this feature when you want to run the program until a certain condition, that is either run up to bit or run up to word, is satisfied, or you want to run the program to the position where the break point is set.

7.2 Stop run

Stop while debug is running.

When debug is resumed, it starts from the first step.

7.3 Trace

This is a command that executes debug by a command.

If the program receives a trace command again at the last step, it goes back to the first step and continues the trace.

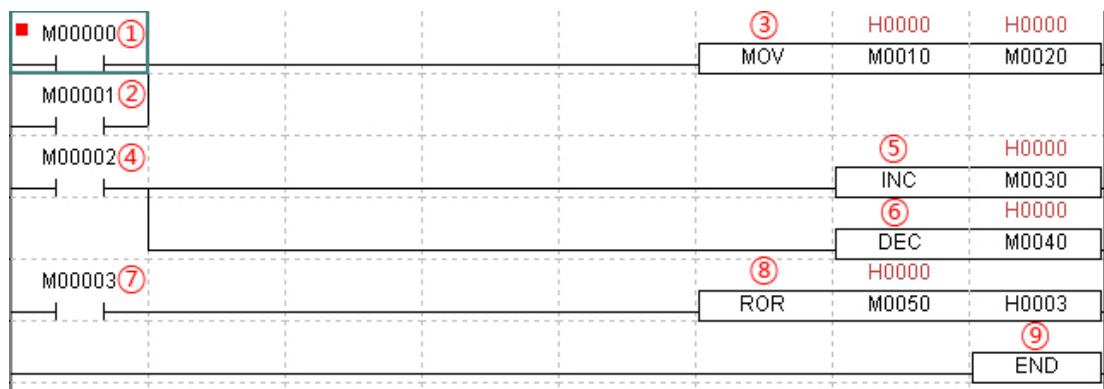

In the above example, it starts tracing from ①), executes to the END instruction at ⑨ in order, and executes ① instruction again.

7.4 Insert/Remove break point

Inserts a break point to stop debugging at the specific step. When a break point is set, the program stops debugging at the position where it encountered the break point while it was operating any of debug run, debug-scan, debug-bit and debug-word. Select [Debug]-[Insert/Remove Break Point] at the specified step, the break point is removed.

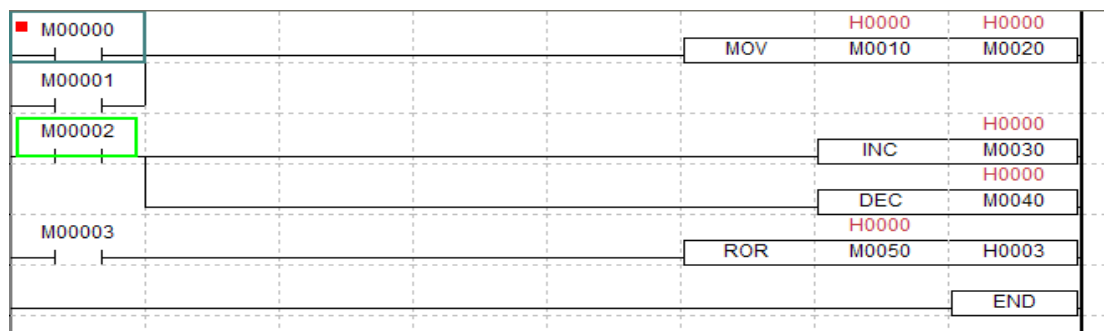

When a break point is inserted, green rectangle appears at cursor position as the above image.

7.5 Stop Debugging

Stops debug mode and switches the mode to STOP.

7.6 Debug-step

Makes the debug run execute to the specific step number in debug mode. Starting step number could be selected in either the stopped step or the first step.



Debug-step	Description
① Step no.	Specify the step number where to start debugging. In the case of the specified step number being greater than the number of the entire steps, it executes 1 scan and stops at step 0.
② From the first step	If you choose the first step as the debug starting step, it jumps from the current step to step 0, and executes to the specified step at ①.
③ From the broken step	If you choose the stopped step as the debug starting step, it executes from the current step to the specified step at ①. If the specified step is located ahead of the stopped step, it executes 1 scan and then executes from the next scan to the specified step.

7.7 Debug-line

Executes the debug by the line(rung). It executes debugging line by a line in order and then moves the break point.

In the image below you can check that debug by the line started at step 7, in mnemonic editor, and the break point moved to step 16. In the mnemonic editor, it executes debugging commands for a line and then stops.



Ex.

- Before debug-line

Step	Instruction	OP1	Pres...	OP2	Pres...	OP3	Pres...	OP4
0	LOAD	M00000	OFF					
1	OR	M00001	OFF					
2	MOV	M0010	H0000	M0020	H0000			
7	LOAD	M00002	OFF					
8	MPIUSH							
9	INC	M0030	H0000					
12	MPOP							
13	DEC	M0040	H0000					
16	LOAD	M00003	OFF					
17	ROR	M0050	H0000	H0003				
22	END							

- After debug-line

Step	Instruction	OP1	Pres...	OP2	Pres...	OP3	Pres...	OP4
0	LOAD	M00000	OFF					
1	OR	M00001	OFF					
2	MOV	M0010	H0000	M0020	H0000			
7	LOAD	M00002	OFF					
8	MPIUSH							
9	INC	M0030	H0000					
12	MPOP							
13	DEC	M0040	H0000					
16	LOAD	M00003	OFF					
17	ROR	M0050	H0000	H0003				
22	END							

7.8 Debug-Scan

Executes program in debugging status for the specified number of scans.



Debug-scan	Description
①The number of scan	Specify the number of scans.
②From the first step	Starts debug from the first step.
③From the broken step	After scanning from the stopped step to the number of scans, it stops debug at the stopped step.

7.9 Debug-1 scan

Executes 1 scan at the stopped step and stops at the original step (the stopped step).

7.10 Step in

This traces into the inside of the operating function from the point of user function call or sub-routine call while debugging.

If the step in is not available at the step on which you tried to step in, it works the same way as a trace.

- Before step in

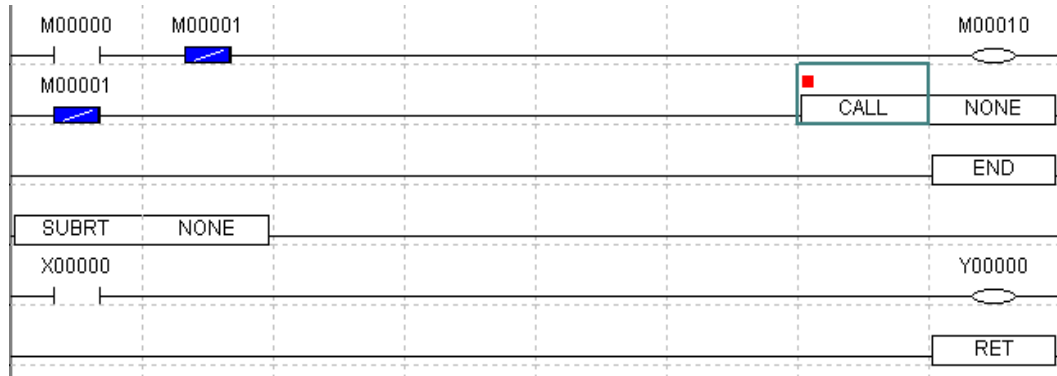

- After step in

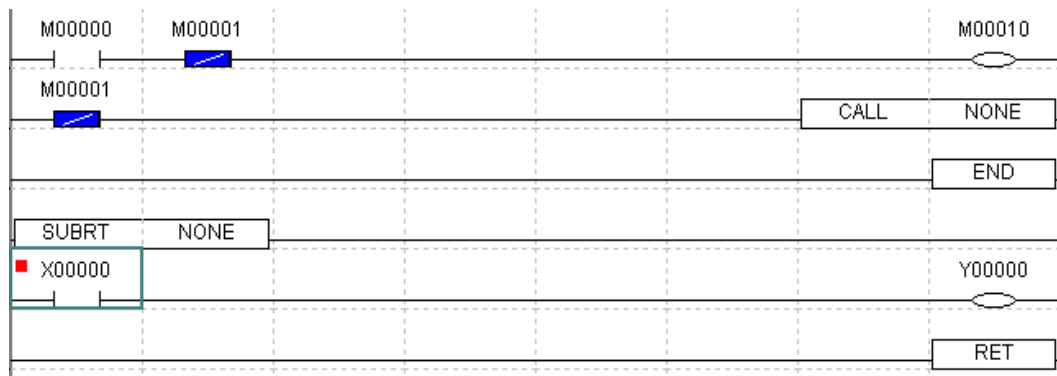

7.12 Debug-bit

Keeps debugging until the device reaches the specified value. Registers the bit device's break registration condition.

Registered break registration condition is deleted when the system operation mode is changed.

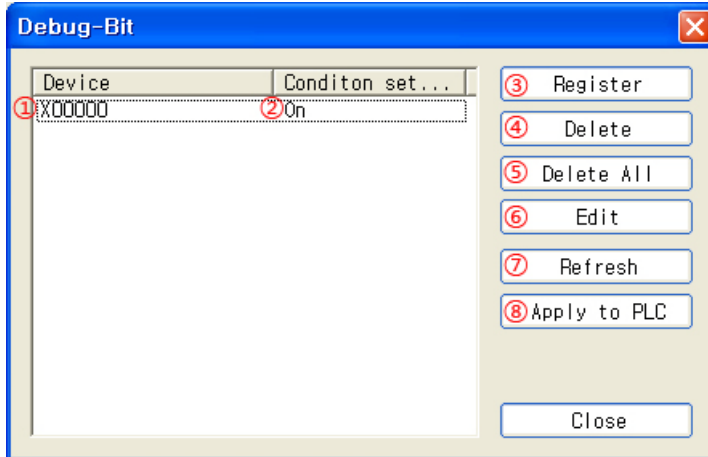

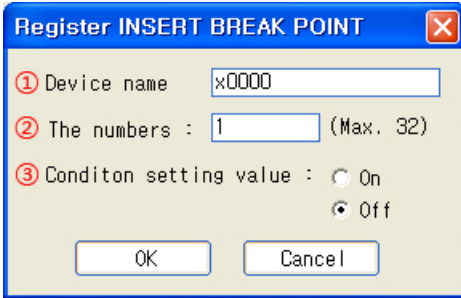
Debug-bit	Description
①,② Device condition setting	Displays registered bit device and break condition.
③ Register	<p>Register new bit device break condition. Click ③ and 'Register INSERT BREAK POINT' dialog box appears.</p>  <p>① Device name: The bit device on which a break condition is registered.</p> <p>② The numbers: Number of devices to be consecutively registered from the device specified in ①. Maximum 32 devices are allowed.</p> <p>③ Condition setting value: Break condition (Off/ On)</p>
④ Delete	Deletes a selected condition from registered conditions.
⑤ Delete All	Deletes all registered conditions.
⑥ Edit	Edits a selected condition from registered conditions.
⑦ Refresh	Reads registered condition from the system and refreshes that condition.
⑧ Apply to PLC	Applies registered condition to the LP system.

7.13 Debug-word

Keeps debugging until the word device reaches the specified value.

Registers a break condition of the word device. The registered break registration condition is deleted when the system operation mode changes.

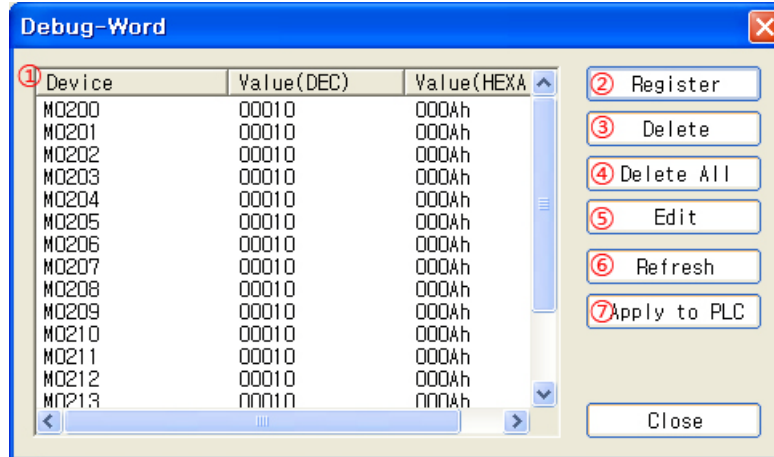

Debug-word	Description
① Word device break condition	Displays registered break condition of the word device by reading registered information of LP.
③ Register	Registers a new break condition of the word device. Click ② and 'Register INSERT BREAK POINT' dialog box appears. <div data-bbox="577 1093 1043 1391" data-label="Image"> </div> <p>① Device name: The word device on which a word break information is registered.</p> <p>② The numbers: Number of devices to be consecutively registered from the device specified in ①. Maximum 32 devices are allowed.</p> <p>③ Condition setting value: Break value of the device.</p>
④ Delete	Deletes a selected condition from registered conditions.
⑤ Delete All	Deletes all registered conditions.
⑥ Edit	Edits a selected condition from registered conditions.
⑦ Refresh	Reads registered condition from the system and refreshes that condition.
⑧ Apply to PLC	Applies registered condition to the LP system.

7.14 Forced I/O settings

This function is for controlling the device signal value for input/output by force. The registered device information by forced I/O settings is cleared when changing LP operation mode.

Select [Debug]-[Forced I/O Settings] of menu or click with right mouse button, 'Forced I/O Settings' dialog box appears.

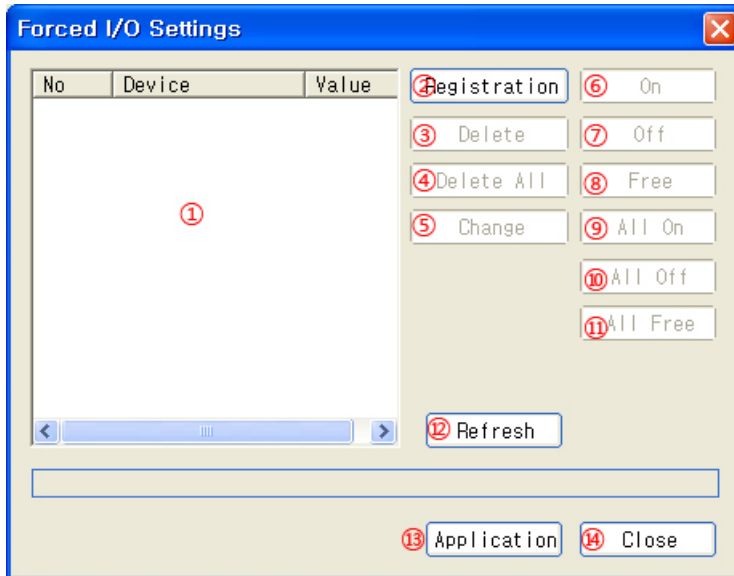

(1) Calls by [Debug]-[Forced I/O Settings] of menu

Forced I/O	Description
① I/O setting	Displays the registered forced I/O setting value on the list
② Registration	Adds new forced I/O
③ Delete	Deletes the selected I/O from the registered forced I/O list in ①
④ Delete All	Deletes all I/O from the registered forced I/O list in ①
⑤ Change	Edits the I/O from the registered forced I/O list in ①
⑥ On	Turns ON the selected I/O from the registered forced I/O list in ① by force
⑦ Off	Turns OFF the selected I/O from the registered forced I/O list in ① by force
⑧ Free	Releases control to the selected I/O from the registered forced I/O list in ①
⑨ All On	Turns ON all I/O from the registered forced I/O list in ①
⑩ All Off	Turns OFF all I/O from the registered forced I/O list in ①
⑪ All Free	Releases control to all I/O from the registered forced I/O list in ①
⑫ Refresh	Reads the registered I/O information from the LP system and refreshes ① I/O setting value list
⑬ Application	Applies the registered I/O information in ① to PLC
⑭ Close	Closes 'Forced I/O Setting' dialog box.

8 Window

8.1 Cascade

This cascade option aligns opened windows like the image below.

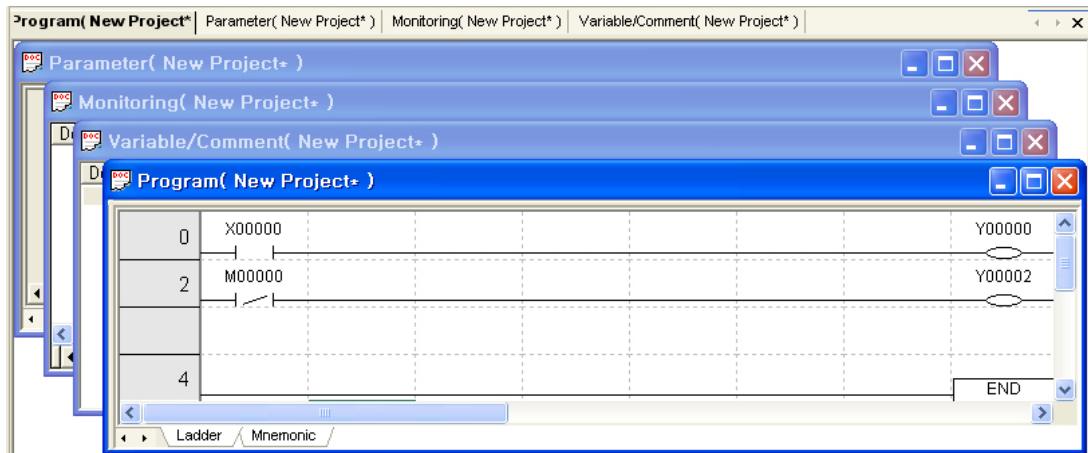

8.2 Horizontal tile

Select [Window]-[Horizontal Tile] of menu, it aligns opened windows like the image below.

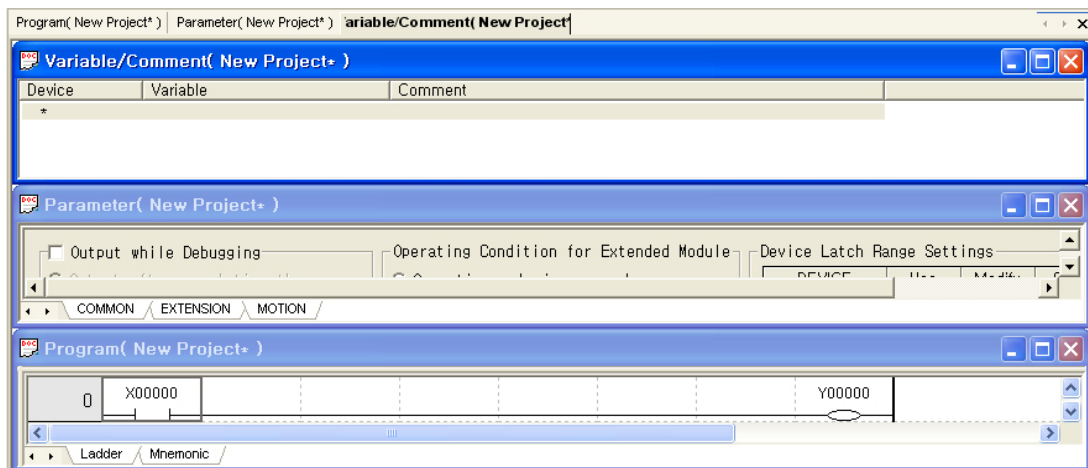

8.3 Vertical tile

Select [Window]-[Vertical Tile] of menu, it aligns opened windows like the image below.

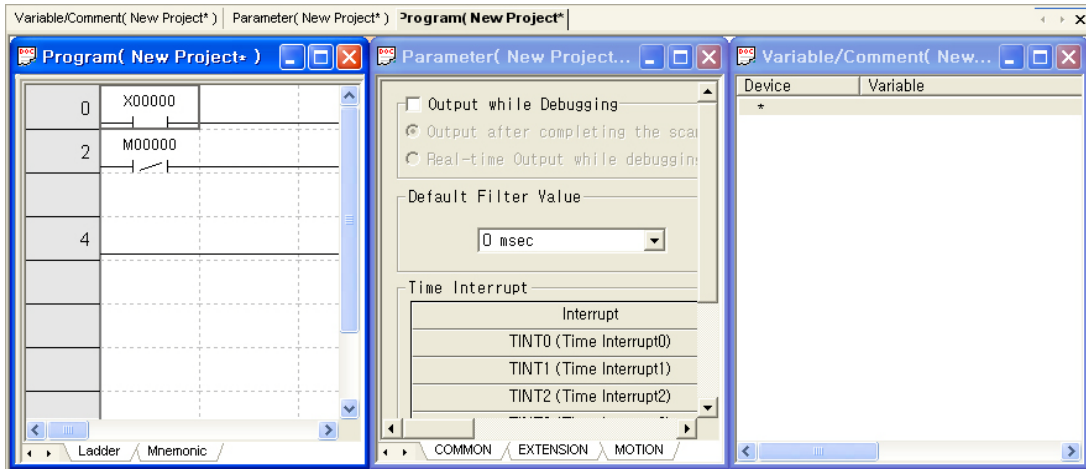

8.4 Arrange icon

Select [Window]-[Arrange Icon] of menu, minimized icons are aligned as below.

- Before arrange icon

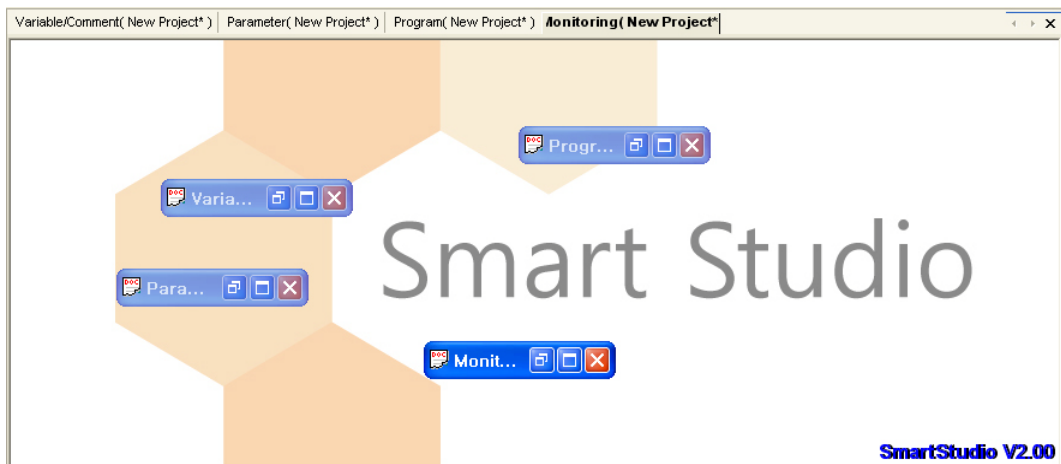

- After arrange icon



8.5 External program connection

This feature allows registering of other programs in order to run them in SmartStudio.

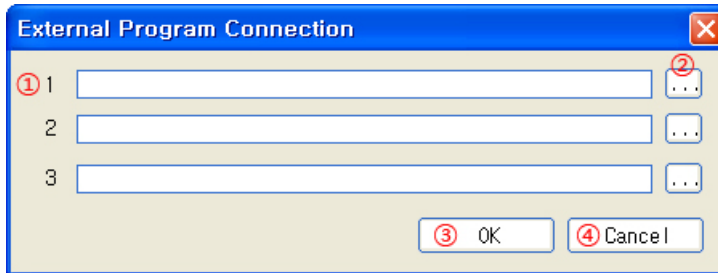

External program connection	Description
① Path	A path to the external program appears. You can directly enter the external program. Registered external program operates directly when clicking the icon in toolbar.
② Browse	Browses external program to be registered by window explorer.
③ OK	Registers the external program and closes 'External Program Connection' dialog box.
④ Cancel	Cancels the registration and closes 'External Program Connection' dialog box.

9 Workspace

9.1 Ladder/Mnemonic program

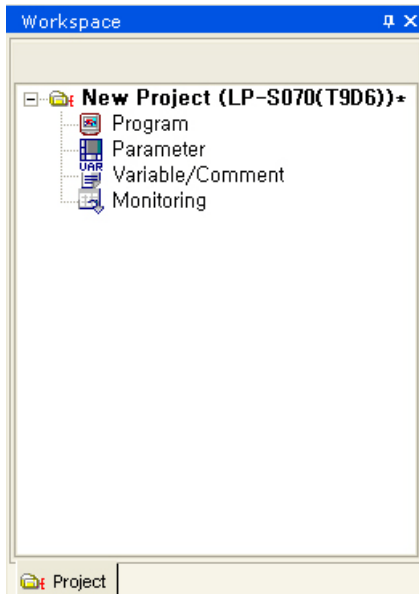

When you select 'Program' in workspace, ladder or mnemonic window opens by program type.

[Ladder program window]

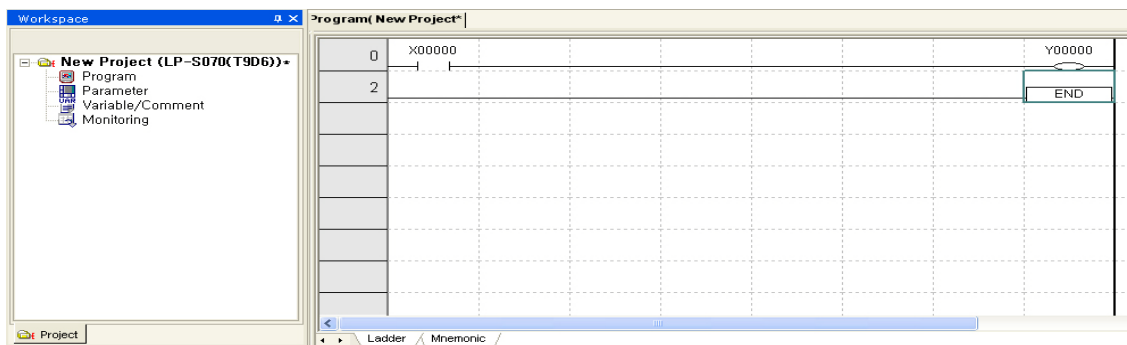

[Mnemonic program window]

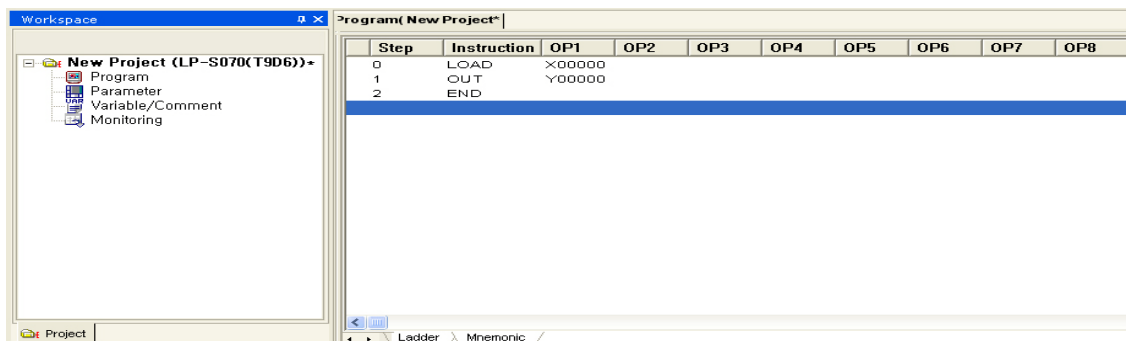

You can input instruction by pressing Enter keyboard or double-clicking in mnemonic editor. After inputting mnemonic, press Enter keyboard. If mnemonic grammar is correct, input is complete. If there is error in mnemonic grammar, grammar checking message appears and it returns to edit window.

9.2 Variable/Comment

When you select 'Variable/Comment' in workspace, the following screen opens.

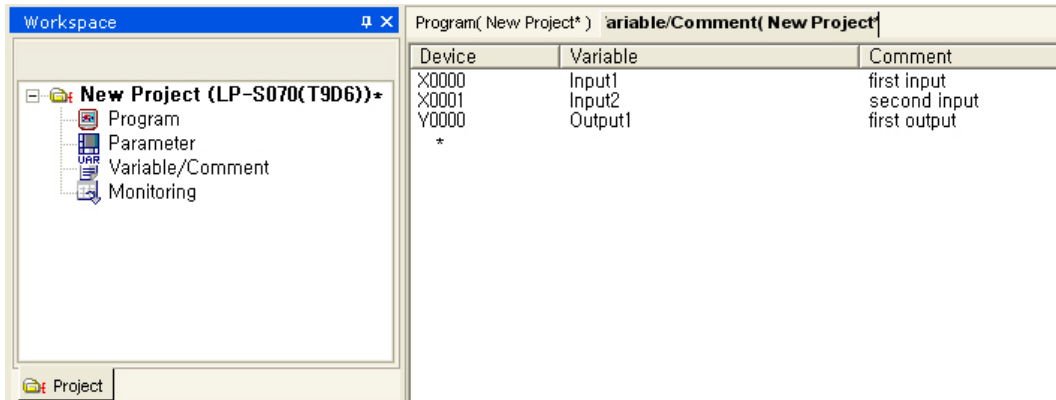

The window outputs existing variables and descriptions. To enter a new variable, double-click the edit window or press Enter keyboard and 'Device' dialog box appears as below.

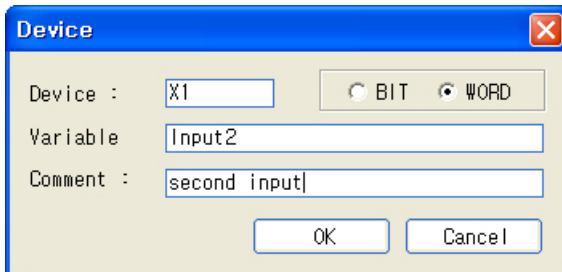

- 1st Enter the device to register as variable and select 'BIT' or 'WORD'.
- 2nd Enter variable name and comment of to be registered and click 'OK'. These input contents are registered and displayed in 'Variable/Comment' edit window.
- 3rd Registered variables are aligned in ascending order by variable name.



Note

Variable name consists of English alphabet , number and underbar(_).

9.3 Monitoring

When you select 'Monitoring' in workspace, the following screen opens.

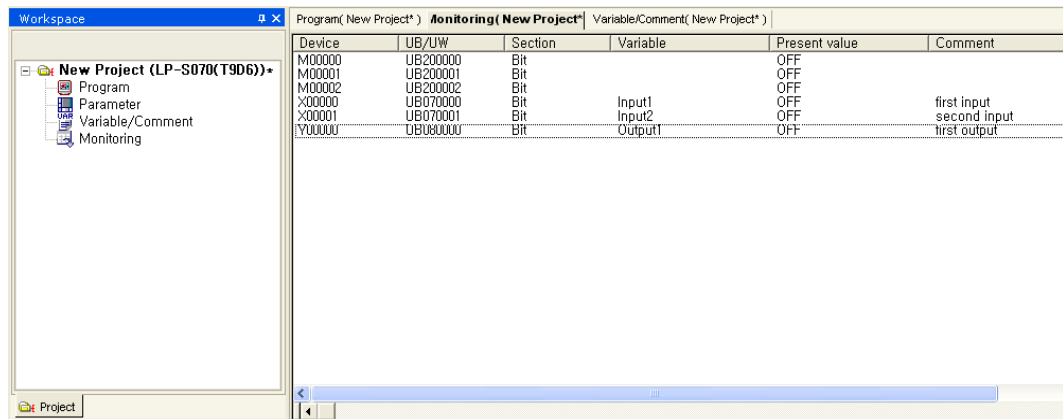

On the monitoring window, devices registered as monitoring devices are displayed. At the time of monitoring LP in SmartStudio, you can monitor the present value of the registered devices.

Double-click the edit window or press Enter keyboard and 'Register Monitor Device' dialog box appears as below.

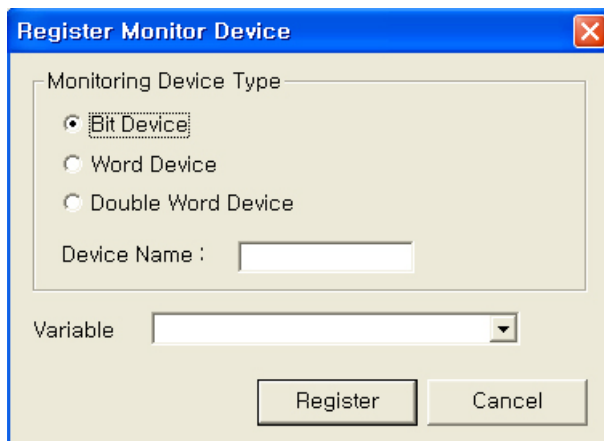

Select monitoring device type; bit device, word device, double word device, enter the device name and click 'Register' and it is registered as monitoring device.

If you want to register consecutive devices, enter [Device - Device] (ex: x0-x5) in the Device Name field. It registers from the first device (x0) to the last device (x5).

If the device you want to register has a registered variable, selecting the variable name immediately registers the device.

Devices in monitoring window are aligned in ascending order by device name.

9.4 Parameter

When you select 'Parameter' in workspace, you can set the detailed configuraiton for LP.

9.4.1 Common

Sets parameters commonly applied to all LP series models.

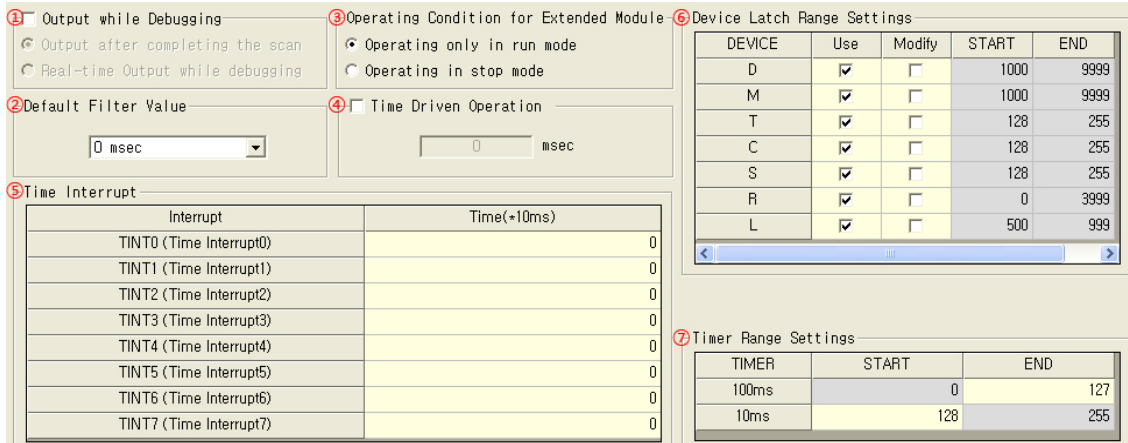

Common	Description
① Output while Debugging	<p>Designate while debugging, output after completing the scan or real-time output.</p> <ul style="list-style-type: none"> Output after completing the scan: Outputs the value of the present output device (Y device) after a scan in debug mode is complete. Real-time Output while debugging: Outputs the value when the value of the output device is changed in debug mode while debugging, regardless of the present debugging position.
② Default Filter Value	<p>The filter value of each input port can be specified per port through the filter function. When you did not individually specify the input port value, the value specified in this item is assigned as a filter value. When '0' is set, it does not use filter value.</p>
③ Operating Condition for Extended Module	<p>This parameter is used to determine how the extension slot is operated according to the system's RUN/STOP mode.</p> <ul style="list-style-type: none"> Operating only in run mode: The extension slot is operated only when LP operation mode is RUN. Operating in stop mode: The extension slot is operated when LP operation mode is set to STOP as well as RUN.
④ Time Driven Operation	<p>A parameter to operate the LP logic program on a fixed cycle execution time.</p>
⑤ Time Interrupt	<p>Designate interrupt occurring interval of specified timer interrupt. Interrupt sources in a fixed cycle total 8, and the interrupt interval can be set in 10 ms increments from 10ms to 655350ms. Interrupt occurs in the interval of the time set and executes interrupt routine. For further details of interrupt instruction, refer to "SmartStudio programming manual" or "LP series instruction manual".</p>
⑥ Device Latch Range Settings*1	<p>Indicates the latch range that the LP has by default. Check 'Use' of each device and the device becomes memory protection device and, it maintains the previous value even though power is OFF to ON. D : 1000 to 9999, M: 1000 to 9999, T: 127 to 255, C: 127 to 255, S: 127 to 255, R: 0 to 3999, L: 500 to 999</p>

Common	Description						
⑦ Timer Range Settings	<p>Timer device area of the designated range has the appropriate time cycle. LP series supports 256 timers from 0 to 255.</p> <p>LP timer is two types; 100ms type, and 10ms type.</p> <p>Depending on using frequency, 256 timers are divided as two types. First allotted contents of 0 to 127 timers are 100ms type, 128 to 255 timers are 10ms type. You can designate the boundary between 100ms type timer and 10ms type timer.</p> <table border="1"> <thead> <tr> <th>Timer type</th> <th>Available range</th> </tr> </thead> <tbody> <tr> <td>100ms</td> <td>0 to 254</td> </tr> <tr> <td>10ms</td> <td>1 to 255</td> </tr> </tbody> </table>	Timer type	Available range	100ms	0 to 254	10ms	1 to 255
Timer type	Available range						
100ms	0 to 254						
10ms	1 to 255						

※1. Caution for time driven operation

Check watch dog timer value and designate time driven operation time to shorter than watchdog timer setting. If you set the time driven operation time is longer than watchdog timer setting, LP operation stops by watchdog timer execution.

Be sure the scan time of program and set the time driven operation time. If you set the time driven operation time is shorter than the execution time of actual program, program may execute unexpected operation.

※2. Caution for latch range setting

- Input/output devices that reference actual input/output port values cannot be set as a latch range.
- Special devices that have influence to the system cannot be set as a latch range, as they operate according to their individual functions when LP restarts after stop or power failure.
- When using latch range, check the remaining battery capacity in [Diagnostics]-[Battery remaining] of system menu in LP.

9.4.2 Extension

Sets expansion function that is classified by type within LP series.

User Defined Slot(Information to be downloaded)

Slot			
1	IN16/OUT16	DEFAULT	Settings
2	[NONE]		Settings
3	[NONE]		Settings
4	[NONE]		Settings
5	[NONE]		Settings
6	[NONE]		Settings
7	[NONE]		Settings
8	[NONE]		Settings
9	[NONE]		Settings
10	[NONE]		Settings
11	[NONE]		Settings
12	[NONE]		Settings
13	[NONE]		Settings
14	[NONE]		Settings
15	[NONE]		Settings
16	[NONE]		Settings

The above image shows available slots in LP series.

The default of LP-044 series is TYPE A, the default of LP-070 series is DEFAULT.

Click 'Settings' and 'I/O Contact Setting' dialog box appears by depending on the LP series.

(1) FILTER

This is a function used to set input filter value. You can set X0 to X7 and X8 to XF filter values respectively. With non-checking 'Using Filter', input filter of extension slot is operated by 'Default filter value' in 'Common' tab.

With checking 'Using Internal Device', the set filter value is saved in the designated inner device in order. By the logic to change this inner device value in ladder program, you can control filter value.

- LP-S044 series

- LP-S070 series

**Ex.**

With checking using inner device, and setting inner device as M0000,
 M0000 ← filter value of X0000 to X00007
 M0001 ← filter value of X0008 to X0000F are saved.

To control filter value by program with checking using inner device, you should write the program as following steps.

- 1st Change M device which is to be inner device as changed filter value. Filter value is available only 0 to 63(6bit) value. Please refer to below table of actual filter value by filter when setting filter value.

Filter time (ms)	Actual filter value
0	0
1	1
2	4
3	6
4	9
5	11
6	14
7	17
8	19
9	22
10	24
15	37
20	52

- 2nd Give pulse input to special device F00090 to set using an internal device with slot 0 module function. Then the value of M device used as an internal device is applied as a filter value.

(2) INTERRUPT

This sets an input contact as an external interrupt.

With checking 'Using Interrupt' and double-click the type and pull-down menu appears to select one; No Int., Falling, or Rising. You can designate the output by two X0 and X1, X2 and X3.

Designate the device with checking 'Using internal device', the earlier set setting values are saved in 2 word by 2 bit of the appropriate device in order.

- LP-S044 series

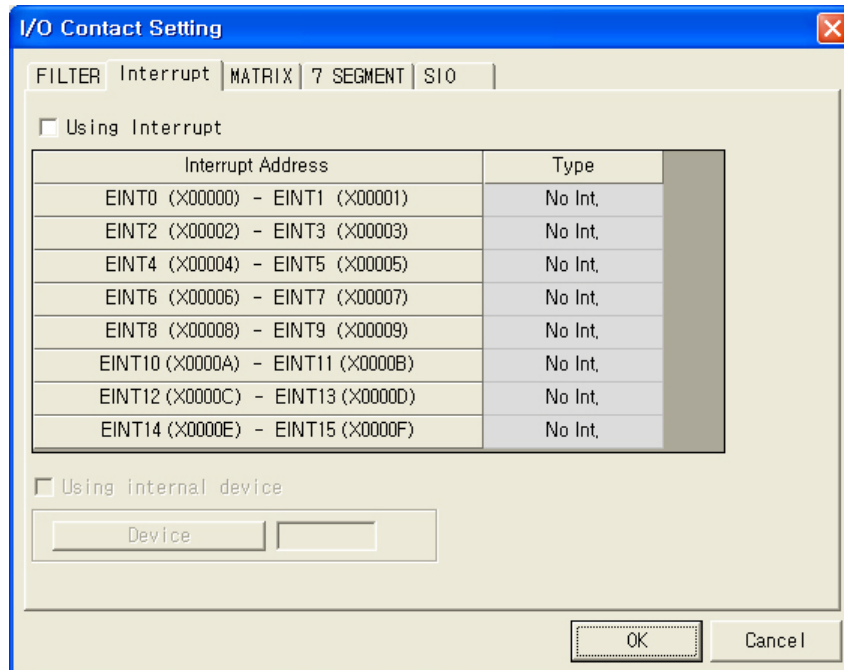

- LP-S070 series

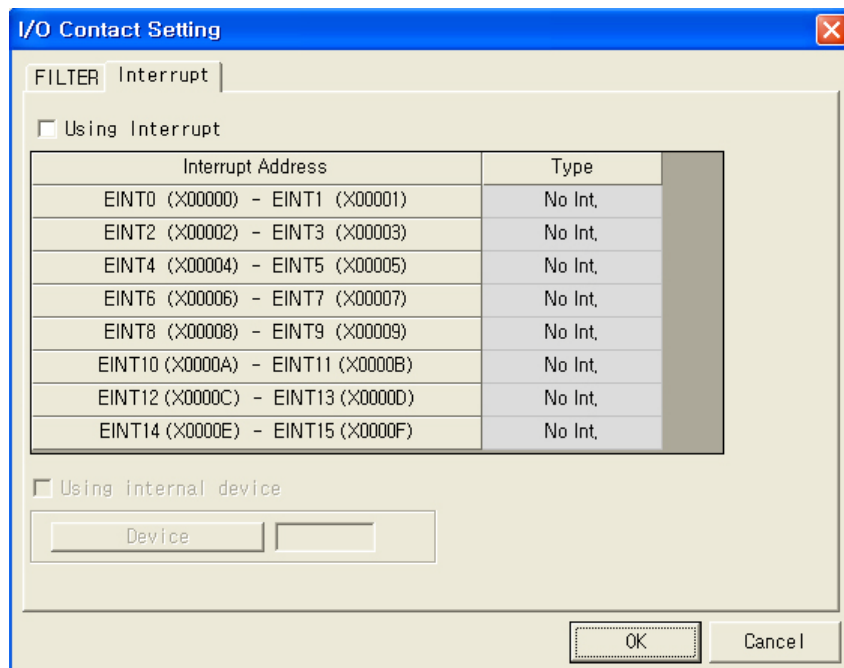



Ex.

This is a mapping example in which the internal device is set to M0100.

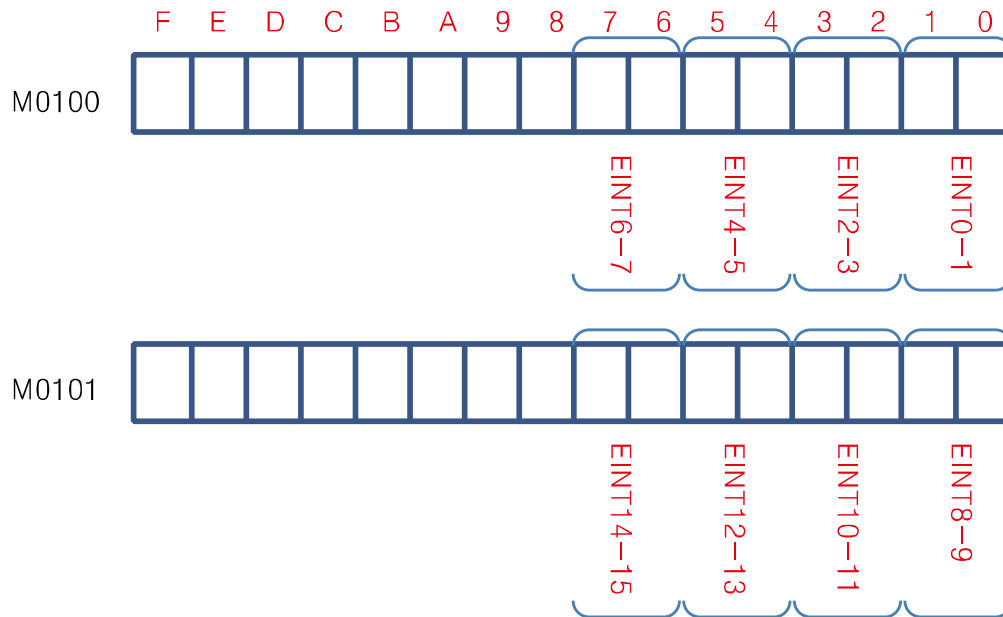

You can control the interrupt values by changing this internal device value in the Ladder program. The method to use an internal device and control the interrupt value with the program is the same as the one used for filter value.

(3) MATRIX

This tab is only for LP-S044 series.

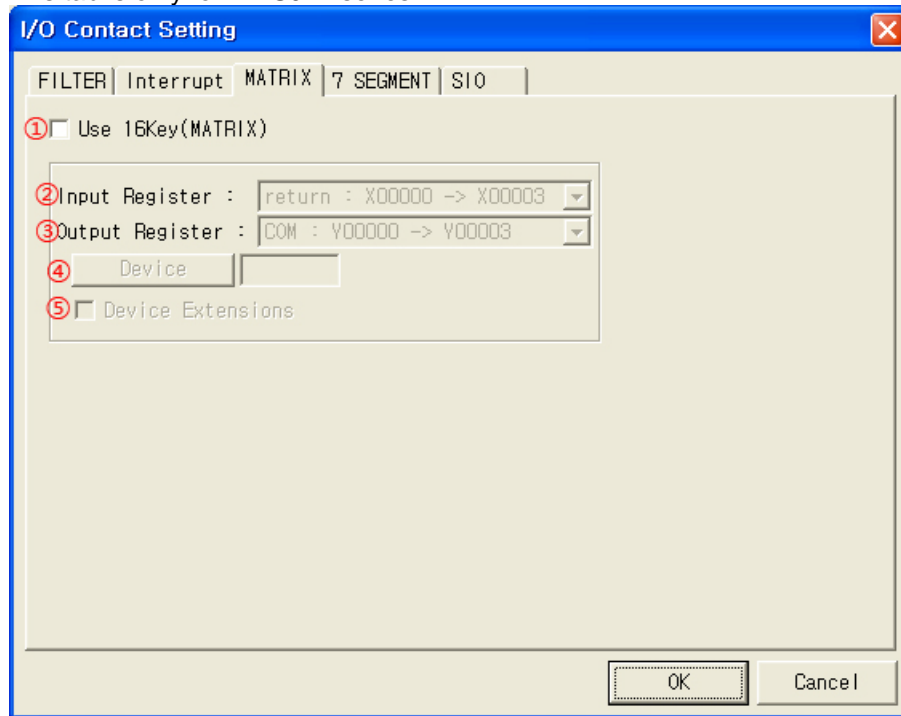

MATRIX tab	Setting range	Description
① Use 16Key (MATRIX)	<ul style="list-style-type: none"> Checking: Use Non-checking: Not use 	Choose whether to use matrix function or not.
② Input Register	<ul style="list-style-type: none"> return : X00000 → X00003: Set X0 to X3 as return input return : X00008 → X0000B: Set X8 to XB as return input 	Select matrix return input signal.
③ Output Register	<ul style="list-style-type: none"> COM : Y00000 → Y00003: Set Y0 to Y3 as COM output COM : Y00008 → Y0000B: Set Y8 to YB as COM output 	Select matrix COM output signal.
④ Device	Select M device	Select M device as a device to save 16 bit key input values.
⑤ Device Extensions* ¹	<ul style="list-style-type: none"> Check: Applies key input value and extended setting information Non-check: Applies only key input value 	Save input register and output register information in the expansion device.

※1. The contents of a device when checking 'Device Extensions'

- WDS: word device lead address: The set device in device item in matrix setting.
- WDS[0] to WDS[F]: word device bit

Using device extensions	<p>WDS: [If input register setting is X0 to X3, it saves 0. If input register setting is X8 to XB, it saves 1.]</p> <p>WDS+1: [If output register setting is Y0 to Y3, it saves 0. If output register setting is Y8 to YB, it saves 1.]</p> <p>WDS+2[0]: [ON when pressing no. 0 switch is detected.]</p> <p>WDS+2[1]: [ON when pressing no. 1 switch is detected.]</p> <p>WDS+2[2]: [ON when pressing no. 2 switch is detected.]</p> <p>....</p> <p>WDS+2[E]: [ON when pressing no. E switch is detected.]</p> <p>WDS+2[F]: [ON when pressing no. F switch is detected.]</p>
Not using device extensions	<p>WDS[0]: [ON when pressing no. 0 switch is detected.]</p> <p>WDS[1]: [ON when pressing no. 1 switch is detected.]</p> <p>WDS[2]: [ON when pressing no. 2 switch is detected.]</p> <p>....</p> <p>WDS[E]: [ON when pressing no. E switch is detected.]</p> <p>WDS[F]: [ON when pressing no. F switch is detected.]</p>

[Matrix connection diagram]

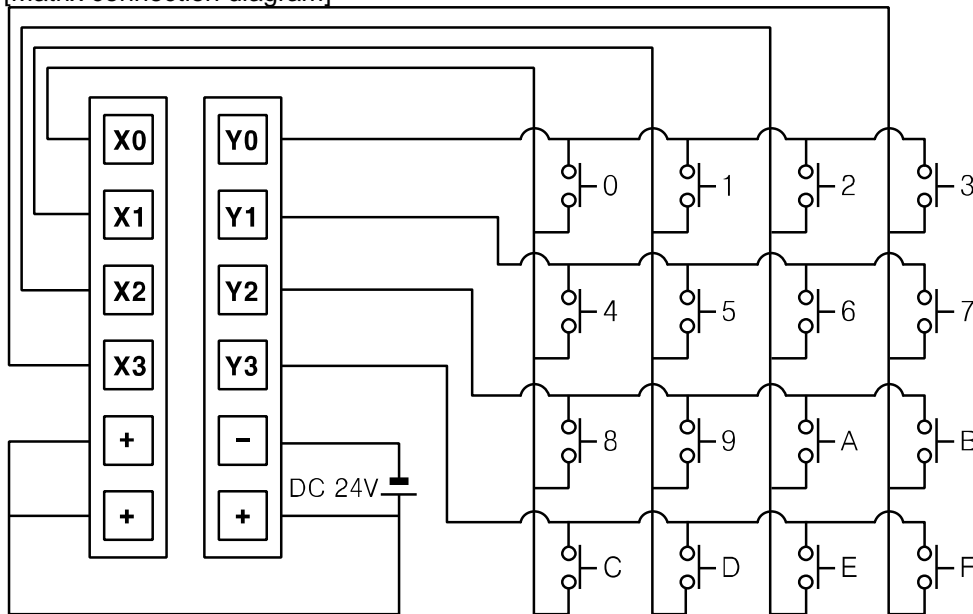

[Save method of input value]

After setting input register as X0 to X3, output register as Y0 to Y3, and device as M0, wire it as above connection diagram. This is the operation description.



When press no. 2, no. 8, no. B keys at the same time;

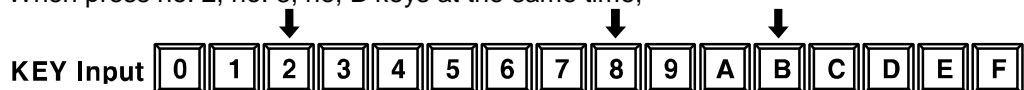

The result of key input is that 2nd, 8th, Bth bit of word device M0 turn ON and M0 value of word device is changed as 0x0904.

(4) 7 segment

This tab is only for LP-S044 series.
This tab is for controlling 7 segment.

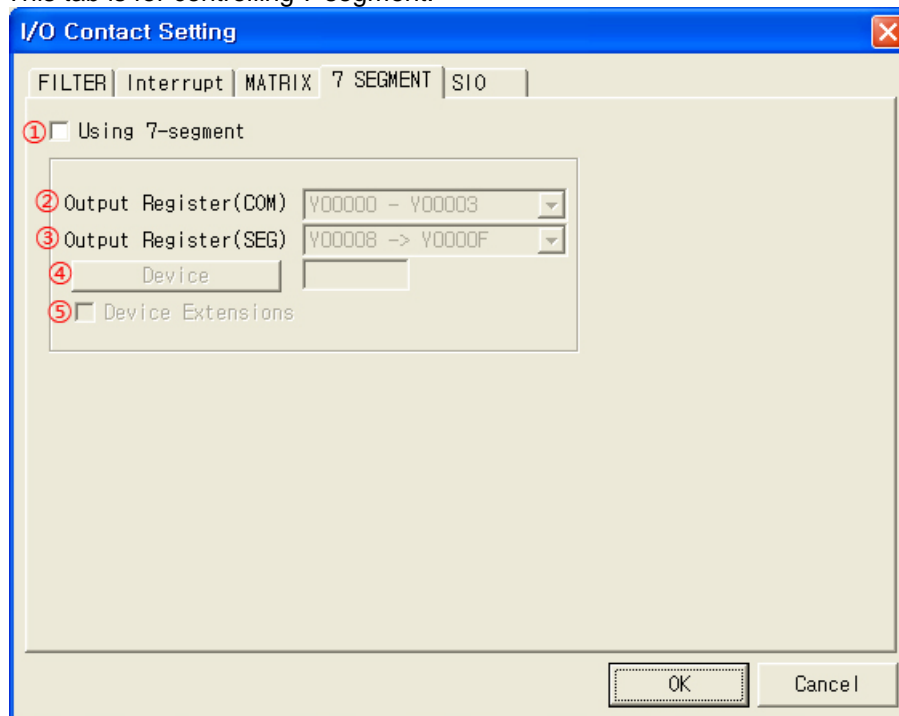

7 SEGMENT tab	Setting range	Description
① Using 7-segment	<ul style="list-style-type: none"> Checking: Use Non-checking: Not use 	Choose whether to use the segment feature or not.
② Output Register (COM)	<ul style="list-style-type: none"> Y00000–Y00003: Set Y0 to Y3 as latch output Y00008–Y0000B: Set Y8 to YB as latch output 	Choose whether to use the segment feature or not.
③ Output Register (SEG)	<ul style="list-style-type: none"> ② Output Register(COM) is set as Y00000–Y00003, it is set as Y00008→Y0000F automatically. ② Output Register(COM) is set as Y00008–Y0000B, it is set as Y00000→Y00007 automatically. 	Select data signal for segment output.
④ Device	Select M device	Taking selected M device as a leading device, select 4-word devices as segment output devices.
⑤ Device Extensions ※1	<ul style="list-style-type: none"> Check: Applies key input value and extended setting information Non-check: Applies only key input value 	Save output register (COM) and output register (SEG) information in the expansion device.

※1. The contents of a device when checking 'Device Extensions'

- WDS: word device lead address: The set device in device item in 7 segment setting.

Using device extensions	WDS: [If output register (COM) setting is Y0 to Y03, it saves 0. If output register (COM) setting is Y8 to YB, it saves 1.] WDS+1: [If output register (SEG) setting is Y8 to YF, it saves 0. If output register (SEG) setting is Y0 to Y7, it saves 1.] WDS+2: [First segment output data] WDS+3: [Second segment output data] WDS+4: [Third segment output data] WDS+5: [Fourth segment output data]
Not using device extensions	WDS: [First segment output data] WDS+1: [Second segment output data] WDS+2: [Third segment output data] WDS+3: [Fourth segment output data]



Ex.

[Setting example and output timing diagram]

Setting item	Setting example
Using 7-segment	Check (Using)
Output Register(COM)	Y00000 - Y00003
Output Register (SEG)	Y00008 -> Y0000F
Device	Inputs M0[0x55], M1[0xAA], M2[0xF0], M3[0x0F] as present value

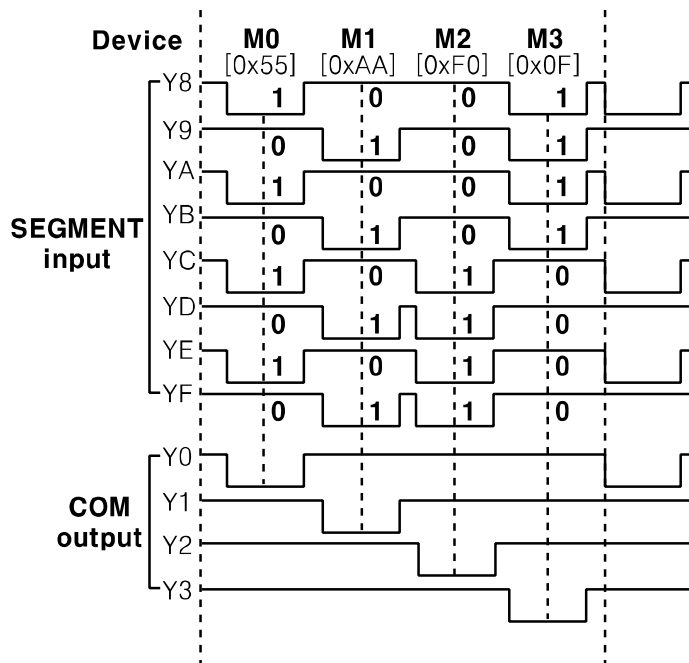

(5) SIO: synchronized signal output

This tab is only for LP-S044 series.

A synchronized signal output function that outputs data according to a specified timing using Clock, Data and Latch signal.

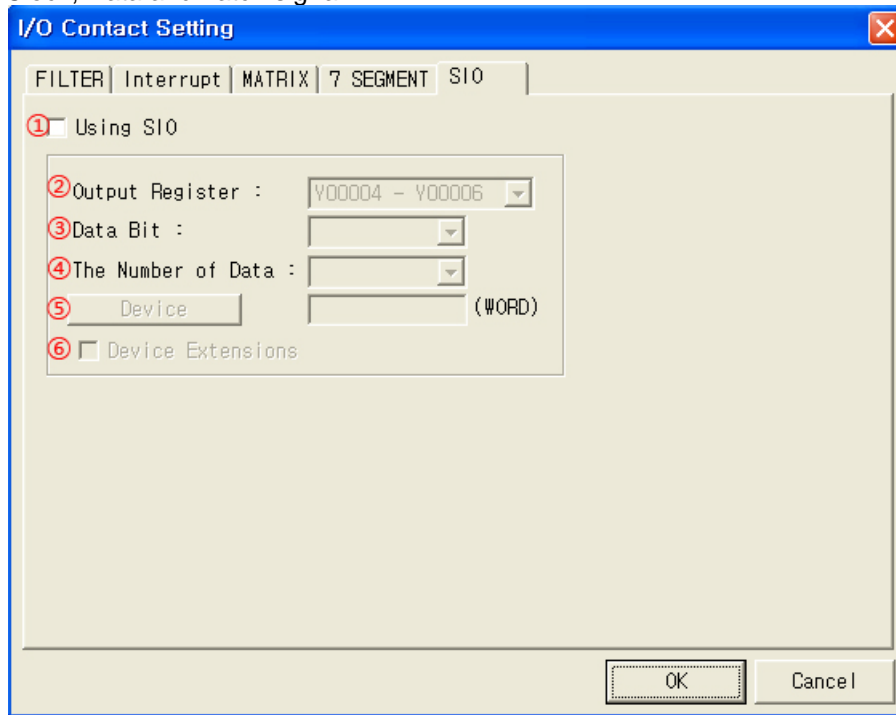

SIO tab	Setting range	Description
① Using SIO	<ul style="list-style-type: none"> Checking: Use Non-checking: Not use 	Choose whether to use the SIO feature or not.
② Output Register	<ul style="list-style-type: none"> Y00004 – Y00006: Clock[Y4], Data[Y5], Latch[Y6] Y0000C – Y0000E: Clock[YC], Data[YD], Latch[YE] 	Select SIO output signal.
③ Data Bit ^{*1}	4 to 7 bit	Selecting data bits
④ The Number of Data	1 to 8 word	Select output data.
⑤ Device	Device lead address	Select heading address of the data to output.
⑥ Device Extensions ^{*2}	<ul style="list-style-type: none"> Check: Applies key input value and extended setting information Non-check: Applies only key input value 	Save information about output register, data bits and amount of data in the expansion device.

※1. Output data information range varies according to set data bits.

Data bit	Available output data range
4 bit	0x000 to 0x000F
5 bit	0x000 to 0x001F
6 bit	0x000 to 0x003F
7 bit	0x000 to 0x007F

※2. The contents of a device when checking 'Device Extensions'

- WDS: word device lead address: The set device in device item in SIO setting.

Using device extensions	WDS: [If output register setting is Y4, Y5, and Y6, it saves 0. If output register setting is YC, YD, and YE, it saves 1.] WDS+1: [Saves the set number of data bits] WDS+2: [Saves the set number of data] WDS+3: [1st display data] ... WDS+n: [(n-3)th display data] *n-3: the number of data
Not using device extensions	WDS: [1st display data] ... WDS+n: [(n-3) th display data] *n : the number of data



Ex.

[Setting example and output timing diagram]

Setting item	Setting example
Using SIO	Check (Using)
Output Register	Y00004 – Y00006
Data Bit	4
The Number of Data	3
Device	D0

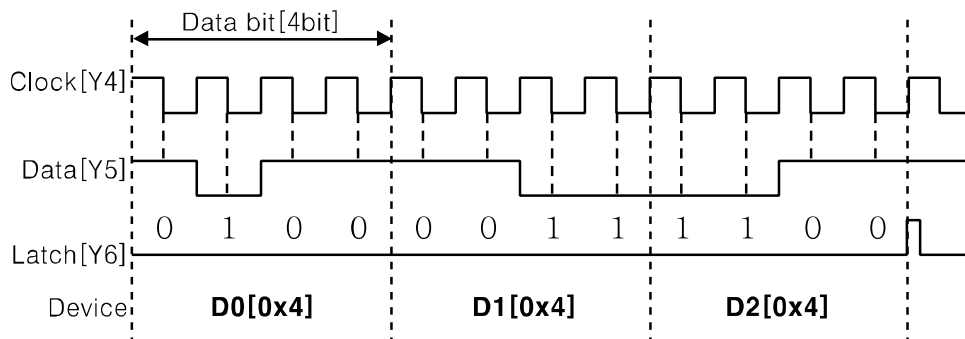

9.4.3 Motion

9.4.3.1 Basic of motion controller

Motion controller is able to move the object from the present to the precision destination position at the desired speed with controlling servo motor or stepping motor.

LP-S070 series includes motion controller function to drive motor driver.

Motion controller function is able to control with basic motion operation as below.

Basic motion drive list (S: start instruction, D: dwell signal, C: complete signal)		
Function	Operation description	Instruction
Position control		MTPDM
	<p>When occurring the rising edge of start instruction, it moves to the desired position with set speed. After dwell time, complete signal is ON with one scan.</p>	
Speed control		MTVDM
	<p>When occurring the rising edge of start instruction, it moves with set speed and decelerates by decelerate stop instructions and stops. Complete signal is ON with one scan.</p>	
Line interpolation drive		MTIPT
	<p>By start instruction, it controls two axes linear interpolation from the present position to the target position.</p>	

Basic motion drive list (S: start instruction, D: dwell signal, C: complete signal)			
Function	Operation description		Instruction
Origin back	Drive type		MTOBC
	Operation	By start instruction, it moves to the returning home direction and detects origin point. The type of origin back direction is according to the 'Common Configuration' of 'MOTION' tab..	
Position override	Drive type		MTOVP
	Operation	By position override instruction, it drives with changing from the original target position to the changed position.	
Speed override	Drive type		MTOVV
	Operation	By speed override instruction, it drives with changing from the present speed to the changed speed.	

LP-S070 series defines that basic motion operations as above are the unit operation, and each unit operation is divided into 3 types which are single, continue and successive.

- Simple: Basic motion operation type is operating only by start instruction.
- Repeat: The motion operation type is operating repeatedly by the first start instruction. Because it goes to the next automatically after finishing every operation for one period, there is dwell time.
- Continuous: As similar as continue type, it has repeated operating by the first starting, but it goes the next without deceleration time and dwell time. Therefore, it is not able to change directions.

Each connection is as below.

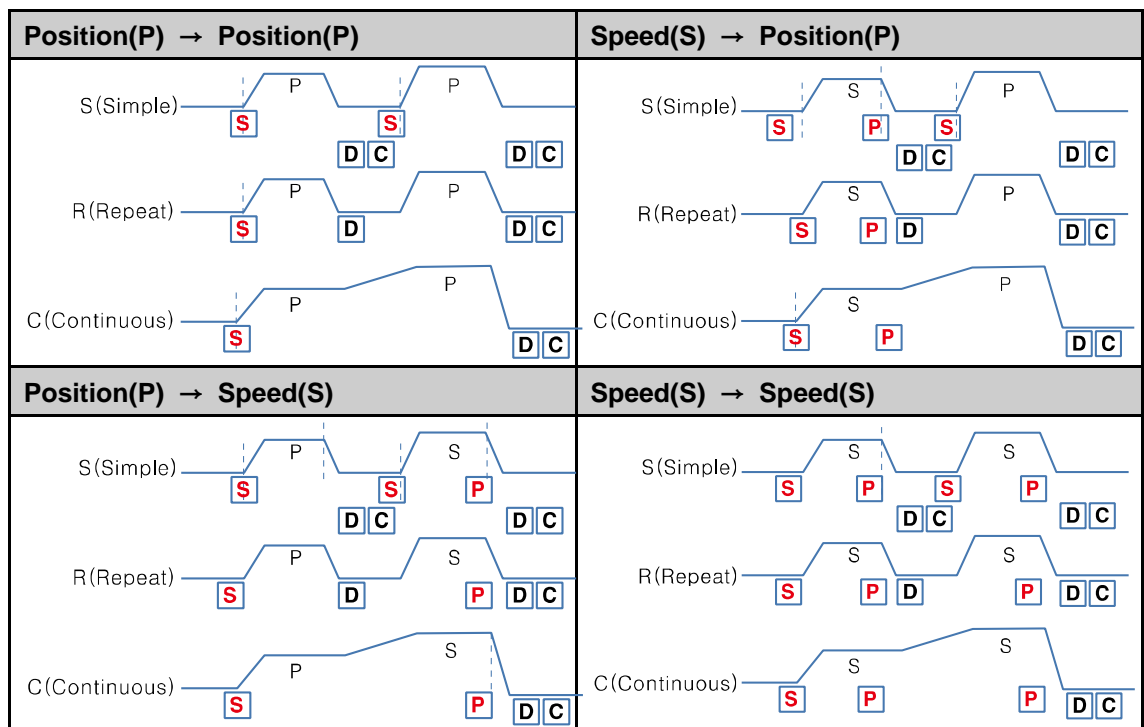

S: Start instruction, **P**: Pause operation instruction, **D**: Dwell signal, **C**: Complete signal
 P: Position Item, S: Speed Item

9.4.3.2 Motion setting parameter

'MOTION' tab in parameter is activated for LP-S070 series type but it is not activated in other series.

You can set basic list for motion control; (1) Common Configuration, (2) Action List, (3) Pattern List.

(1) Common Configuration

Item	Ch1 Axis	Ch2 Axis
Enable Ch	FALSE	FALSE
S/W Upper Limit	2147483647	2147483647
S/W Lower Limit	-2147483647	-2147483647
Start Speed(pps)	0	0
Origin Point	0	0
Home Search Direction	Forward	Forward
Acceleration Time1(ms)	0	0
Acceleration Time2(ms)	0	0
Acceleration Time3(ms)	0	0
Acceleration Time4(ms)	0	0
Acceleration Time5(ms)	0	0
Deceleration Time1(ms)	0	0
Deceleration Time2(ms)	0	0
Deceleration Time3(ms)	0	0
Deceleration Time4(ms)	0	0

(2) Action List

Num	Drv Type	Coordi Type	Dst Pos	Drv Direction	Drv Speed(pps)	#
1	Position	Absolute	0	Forward	0	1
2	Position	Absolute	0	Forward	0	1
3	Position	Absolute	0	Forward	0	1
4	Position	Absolute	0	Forward	0	1
5	Position	Absolute	0	Forward	0	1

(3) Pattern List

No.	Pattern String
1	
2	
3	
4	
5	
6	

Check pattern string grammar

(1) Common configuration

This configuration is basic for using motion in LP-S070, you can set CH1, CH2 operation.

1) Using internal device

Checking 'Using Internal Device', you can directly edit the setting items in LP-S070 system [Parameter]-[Common setting] without SmartStudio after downloading the program in LP.

Check 'Using Internal Device' and 'Device' is activated.

Click 'Device' and 'Select the device' dialog box appears to designate the inner device.

Select the device

M

7	8	9	D	E	F
4	5	6	A	B	C
1	2	3	BACK		
0	CLEAR				

OK Cancel



Ex.

[Device map with checking 'Using Internal Device']

With checking 'Using Internal Device' and designating the device, the setting values of common configuration are saved to from the designated device in order. The below device map is when inner device is set as M100.

M100	Enable Ch
M101	
M102	S/W upper limit
M103	
M104	S/W lower limit
M105	
M106	Start speed
M107	
M108	Origin point
M109	
M110	Home search direction
M111	Acceleration time 1
M112	Acceleration time 2
M113	Acceleration time 3
M114	Acceleration time 4
M115	Acceleration time 5
M116	Deceleration time 1
M117	Deceleration time 2
M118	Deceleration time 3
M119	Deceleration time 4
M120	Deceleration time 5
M121	Jog speed
M122	
M123	Jog acceleration time
M124	Jog deceleration time
M125	Acceleration time to origin
M126	Deceleration time to origin
M127	Home search position
M128	
M129	Enable S/W limit
M130	Enable H/W limit
M131	Origin back kind

2) Common configuration item

Item	Type	Description
Enable Ch	BYTE(1Byte)	Whether to use Ch1, Ch2 or not, motion control or not. <ul style="list-style-type: none"> TRUE: Using it for I/O motion drive FALSE: Using it for I/O
S/W upper limit	DWORD (4Byte)	Designate the movement range of the device as user-defined range by S/W. <ul style="list-style-type: none"> When using S/W limit, if the present position is over S/W upper/lower limit, it executes emergency stop. Set range: -2,147,483,648 to 2,147,483,647
S/W lower limit	DWORD (4Byte)	
Start speed(pps)	Unsigned DWORD (4Byte)	Designate start speed. <ul style="list-style-type: none"> Set range: 100,000 pps
Origin point	DWORD(4Byte)	Designate origin point position. <ul style="list-style-type: none"> Set range: -2,147,483,648 to 2,147,483,647
Home search direction	BYTE(1Byte)	Designate home search direction when using H/W origin back. (Forward /Backward)
Acceleration time1(ms)	Unsigned WORD(2Byte)	Designate acceleration time. <ul style="list-style-type: none"> Set range: 0 to 65535ms This is acceleration time to be taken from stop status(0) to maximum speed (100,000pps). If you set start speed, this acceleration time is to be taken time from the set start speed to maximum speed (100,000pps).
Acceleration time2(ms)	Unsigned WORD(2Byte)	
Acceleration time3(ms)	Unsigned WORD(2Byte)	
Acceleration time4(ms)	Unsigned WORD(2Byte)	
Acceleration time5(ms)	Unsigned WORD(2Byte)	
Deceleration time1(ms)	Unsigned WORD(2Byte)	Designate deceleration time. <ul style="list-style-type: none"> Set range: 0 to 65535ms This is deceleration time to be taken from maximum speed (100,000pps) to stop status (0). If you set start speed, this deceleration time is to be taken time from maximum speed (100,000pps) to the set start speed.
Deceleration time2(ms)	Unsigned WORD(2Byte)	
Deceleration time3(ms)	Unsigned WORD(2Byte)	
Deceleration time4(ms)	Unsigned WORD(2Byte)	
Deceleration time5(ms)	Unsigned WORD(2Byte)	
Jog speed(pps)	Unsigned DWORD (4Byte)	Designate drive speed in jog drive. <ul style="list-style-type: none"> Set range: 1 to max. speed (100,000pps)
Jog acceleration time (ms)	Unsigned WORD(2Byte)	Designate jog acceleration time. <ul style="list-style-type: none"> Set range: 0 to 65535ms
Jog deceleration time (ms)	Unsigned WORD(2Byte)	Designate jog deceleration time. <ul style="list-style-type: none"> Set range: 0 to 65535ms
Acceleration time to origin (ms)	Unsigned WORD(2Byte)	Designate acceleration time to origin. <ul style="list-style-type: none"> Set range: 0 to 65535ms

Item	Type	Description
Deceleration time to origin (ms)	Unsigned WORD(2Byte)	Designate deceleration time to origin. <ul style="list-style-type: none"> Set range: 0 to 65535ms
Home search position (pps)	Unsigned DWORD(4Byte)	Designate the progress speed to back origin point. <ul style="list-style-type: none"> Set range: 0 to max. speed (100,000pps)
Enable S/W limit	BYTE(1Byte)	Whether to use the limit of user-defined drive range by S/W or not. If it is out of the range, it executes emergency stop.
Enable H/W limit	BYTE(1Byte)	Whether to use the limit of user-defined drive range by H/W or not. If it is out of the range, it executes emergency stop.
Origin back kind	BYTE(1Byte)	Select origin back method. <ul style="list-style-type: none"> H/W: Designate the origin point with origin point signal. S/W: Use the user defined origin point on the program.

(2) Action list

Designate basic drive of one period.

- 1) Using internal device

Checking 'Using Internal Device', you can directly edit the setting items in LP-S070 system [Parameter]-[Common setting] without SmartStudio after downloading the program in LP.

Check 'Using Internal Device' and 'Device' is activated.

Num	Drv Type	Coodi Type	Dst Pos	Drv Direction	Drv Speed(pps)	
1	Speed	Absolute	0	Backward	10000	1
2	Position	Relative	40000	Forward	10000	1
3	Position	Absolute	10000	Forward	5000	1

Click 'Device' and 'Select the device' dialog box appears to designate the inner device.



Ex.

[Device map with checking 'Using Internal Device']

With checking 'Using Internal Device' and designating the device, the setting values of common configuration are saved to from the designated device in order. The below device map is when inner device is set as D100.

D0100	Number
D0101	Drive type
D0102	Coordinate type
D0103	Destination position
D0104	
D0105	Drive direction
D0106	Drive speed
D0107	
D0108	Acceleration time
D0109	Deceleration time
D0110	Dwell time

D0100 : Designated inner device

2) Action list item

Item	Description
Num	It is able to set up to 99.
Drive type	<ul style="list-style-type: none"> Position: Drives from present position to the destination position with the defined speed. Speed: Drives from present position with the defined speed and direction.
Coordinate type	<ul style="list-style-type: none"> Absolute: Fixed coordination based on the origin point. Relative: User defined coordination based on the last point.
Destination position	<p>When drive type is 'Position', this item is activated to set destination position.</p> <ul style="list-style-type: none"> Set range: -2,147,483,648 to 2,147,483,647 When drive type is 'Position', it compares present position and destination position to control direction automatically.
Drive direction	<p>When drive type is 'Speed', this item is activated to set drive direction.</p> <ul style="list-style-type: none"> 1: Forward, 0: Backward
Drive speed	<p>Designate drive speed. (Unit: pps)</p> <ul style="list-style-type: none"> Max. range: 100,000pps
Acceleration time	<p>Designate the user defined acceleration time (1 to 5) in 'Common Configuration'.</p> <ul style="list-style-type: none"> Using this, it converts the time to accelerate 100,000pps based on their speed.
Deceleration time	<p>Designate the user defined deceleration time (1 to 5) in 'Common Configuration'.</p> <ul style="list-style-type: none"> Using this, it converts the time to decelerate 100,000pps based on their speed.
Dwell time	<p>Designate dwell time for after completing drive.</p> <ul style="list-style-type: none"> Set range: 0 to 65535ms

 Ex.

Example of motion action by drive type from action list

- ① Drive type: Position, Coordination type: Absolute
 Drives with drive speed (10000pps) and reaches destination position (50000).
 Each item's setting value is as below. (For position drive, it needs to set drive type, coordinate type, destination type, drive speed(pps), accel time, decel time and dwell time(ms) parameters.)

Num	Drv Type	Coordi Type	Dst Pos	Drv Direction	Drv Speed(pps)	Accel Time	Decel Time	Dwell Time(ms)
1	Position	Absolute	50000 ①	Forward	10000 ②	1 ③	1 ④	1000 ⑤

- Drive type: Position drive, when it reaches the destination position, drive is finished.
- Coordination type: Absolute coordination, when it reaches the destination position, drive is finished regardless of present position.
- Destination position: 50000, drive is finished at this position.
- Drive speed: 10000pps, drive speed of motor.
- Accel/Decel time: Selected each one from acceleration time 1 to 5 and deceleration time 1 to 5.
- Dwell time: Stabilization time for next drive after completing motor drive.

The followings are the graph of this example.

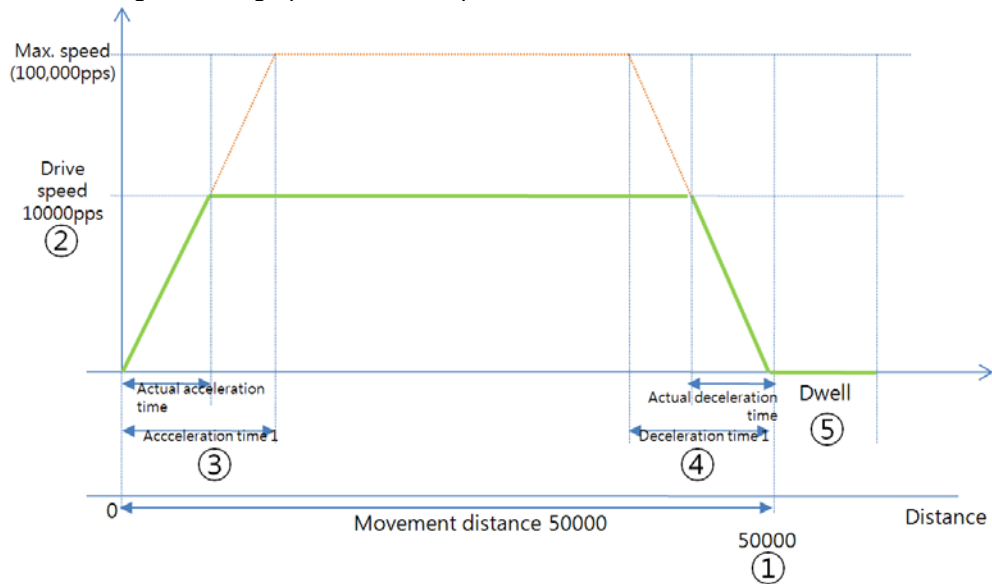

- ② Drive type: Position, Coordination type: Relative
 Drives with drive speed (10000pps) and reaches destination position (50000).
 Each item's setting value is as below. (For position drive, it needs to set drive type, coordinate type, destination type, drive speed(pps), accel time, decel time and dwell time(ms) parameters.)

Num	Drv Type	Coordi Type	Dst Pos	Drv Direction	Drv Speed(pps)	Accel Time	Decel Time	Dwell Time(ms)
1	Position	Relative	50000 ①	Forward	10000 ②	1 ③	1 ④	1000 ⑤

- Drive type: Position drive, when it reaches the destination position, drive is finished.
- Coordination type: Relative coordination.
- Destination position: When coordination type is relative, destination position is movement distance. Therefore, destination position 50000 is same as movement distance 50000.
- Drive speed: 10000pps, drive speed of motor.
- Accel/Decel time: Selected each one from acceleration time 1 to 5 and deceleration time 1 to 5.
- Dwell time: Stabilization time for next drive after completing motor drive.

The followings are the graph of this example. (Present position of this example is 1000.)

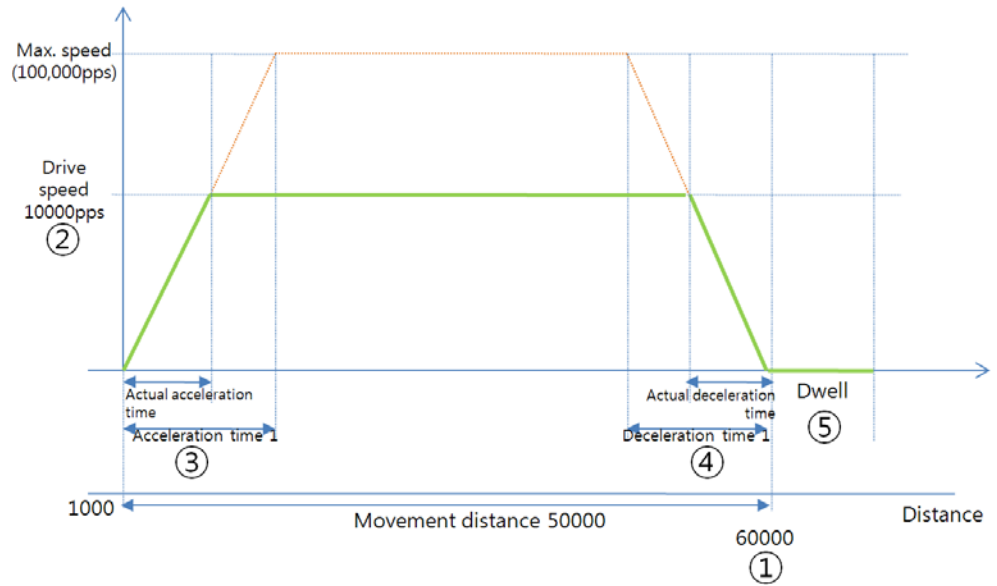

③ Drive type: Speed

This example is speed drive with the designated speed. Each item's setting value is as below. (For speed drive, it needs to set drive type, drive direction, drive speed (pps), accel time, decel time, and dwell time(ms) parameters).

Num	Drv Type	Coodi Type	Dst Pos	Drv Direction	Drv Speed(pps)	Accel Time	Decel Time	Dwell Time(ms)
1	Speed	Absolute	0	Forward	10000 ①	1 ②	1 ③	1000 ④

- Drive type: Speed drive, it drives continuously until complete signal occurs.
- Drive speed: 10000pps, drive speed of motor.
- Accel/Decel time: Selected each one from acceleration time 1 to 5 and deceleration time 1 to 5.
- Dwell time: Stabilization time for next drive after completing motor drive.
- The followings are the graph of this example.

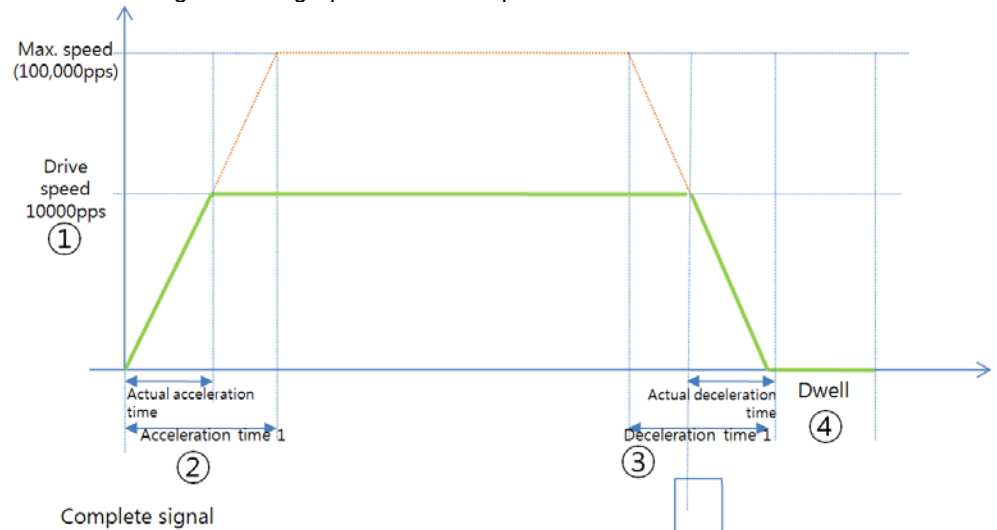

④ To use the saved values of 'Action List'

'Action List' is the setting for motion control. You can actual drive by MTUAI(action list drive) instruction which designates action number to drive, and by MTIDM (Indirect designation drive) with the user-defined pattern list.

(3) Pattern list

This pattern list is able to execute repeated drive and several drives as pattern form by binding action list.

- 1) Pattern list item

Item	Description
Number	It is able to set pattern list number from 1 to 99.
Pattern string	Enters script strings to execute pattern. It has variable length up to 200 characters (byte).

- 2) Check pattern string grammar

This function is check whether each pattern string's grammar is correct or not. If there is no error, "Pattern string has been made correctly" message appears in message box. If there is error, this data is not downloaded to LP.



Ex.

Pattern list (For pattern list structure and writing, refer to '9.4.3.3Pattern writing'.)

No.	Pattern String
1	1
2	1R, 2C, 3, 4
3	C1-2R, 2-3C, 3
4	

9.4.3.3 Pattern writing

LP-S070 saves motor drive information as pattern form and is able to write repeated drive easily.

(1) Unit action

1) Pattern grammar structure

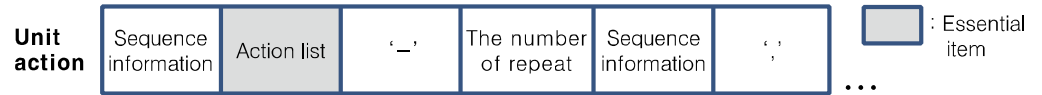

2) Item descriptions

Item	Description
Sequence information (Current pattern)	Designation part for repeat connection information of current pattern with continue, repeat, or single. Continue: C, Repeat: R, Single: None (omissible)
Action list	Designate action list number. (essential)
Signal of the number of repeat "_"	Signal for dividing action list number and the number of repeat. If there is no number of repeat, please omit this.
The number of repeat	The number of repeat for action list (omissible) '0' means infinite repeat.
Sequence information (Next pattern)	Designate connect action for next pattern. If there is no next pattern, it is omissible.
Signal of pattern ",,"	Signal for dividing next unit action. If there is no next action, it is omissible.



[Pattern grammar of unit action]

1) Sequence information (Current pattern)	2) Action List	3) Signal of the number of repeat	4) The number of repeat	5) Sequence information (for next pattern)	6) Signal of pattern ' , '
---	----------------	-----------------------------------	-------------------------	--	----------------------------

C5-2R,2-3C,4

C5-2R,2-3C,4 → 5,C,5,R,2,2,2,C,4

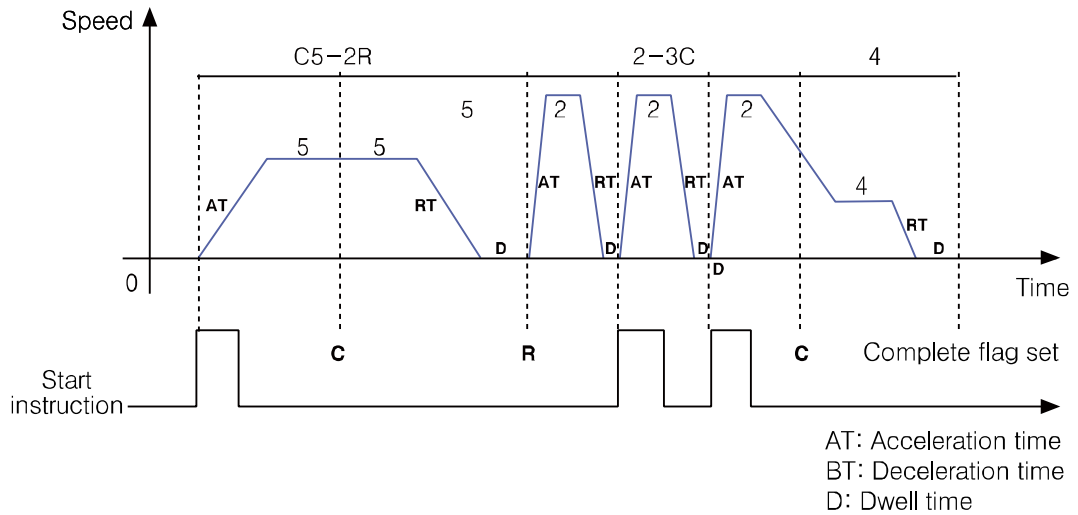

- 1st Repeats #5 action list twice with C(continue).
- 2nd After repeated second #5 action list, connects #2 action list with R(repeat).
- 3rd Repeats #2 action list three times with single.
To repeat action list with single, there should be start instruction to executes the action.
- 4th After repeated third #2 action list, connects #4 action list with C(continue).
- 5th Executes #4 action list once and completes this action.

(2) Group action

1) Pattern grammar structure

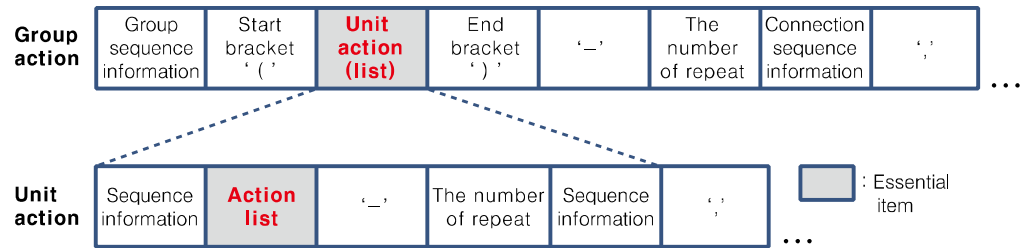

2) Item descriptions

Item	Description
Group sequence information	Designation part for repeat connection information of current pattern Continue: C, Repeat: R, Single: None (Omissible)
Start bracket	When binding several unit actions as one group, this symbolizes the start of this group.
Unit action list	A binding of unit actions
End bracket	When binding several unit actions as one group, this symbolizes the end of this group.
Signal of the number of repeat "-"	Signal for dividing unit action or group action number and the number of repeat.
The number of repeat	The number of repeat for unit action or group action.
Connection sequence information	Designation part for connection information with next items
Signal of pattern ","	Signal for dividing next unit action or group action.



Ex.

[Pattern grammar of group action]

It is able to drive as unit action by binding other unit actions with bracket.

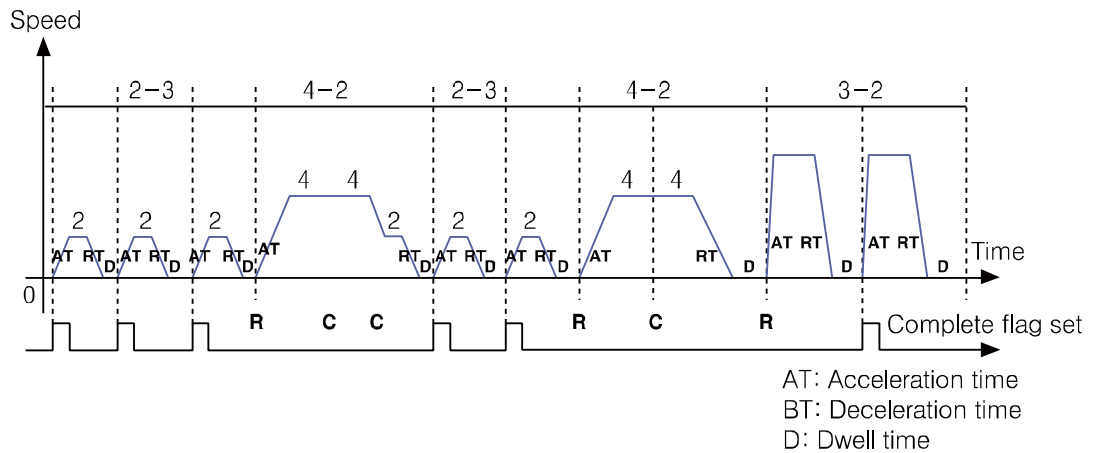
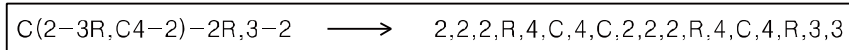
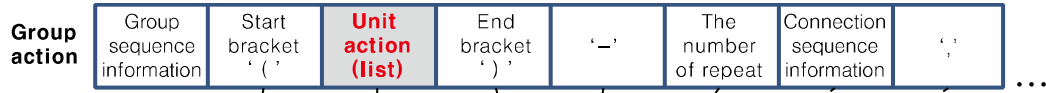

1st Repeats #2 action list three times with single.

To start or repeat action list with single, there should be start instruction to execute the action.

2nd After repeated third #2 actoin list, connects #4 action list with R(repeat).

3rd Repeats #4 action list twice with C(continue).

4th 1st to 3rd steps are binded with start bracket "(" and end bracket ")" as a group action. Repeat this group action 1st to 3rd steps one more with C(continue). (The number of repeat for group action is set two times.)

5th After the last of group action(repeated second #4 action list), connects #3 action list with R(repeat).

6th Repeats #3 action list twice with single.

To repeat action list with single, there should be start instruction to executes the action.



Note

Group pattern grammar does not allow to use double brackets. Therefore, please separate each bracket pair for group pattern grammar.

(Example) $(C(R3-2C,C4-2)-2R)-2C,3-2 \rightarrow C(R3-2C,c4-2)-2C, C(R3-2C,c4-2)-2C,3-2$

(3) Infinite repeat

The number of repeat “0” means infinite repeat in pattern grammar structure. Action list or group action which has the number of repeat “0” is repeated infinitely.



Ex.

[Pattern grammar of group action which has infinite repeat]
 C(2-3, 4-0, 5-2)-0R

Group action	Group sequence information	Start bracket ‘(’	Unit action (list)	End bracket ‘)’	‘-’	The number of repeat	Connection sequence information	...
	$C(2-3, 4-0, 5-2)-0R$							

$C(2-3R, C4-2)-2R, 3-2 \longrightarrow 2, 2, 2, R, 4, C, 4, C, 2, 2, 2, R, 4, C, 4, R, 3, 3$

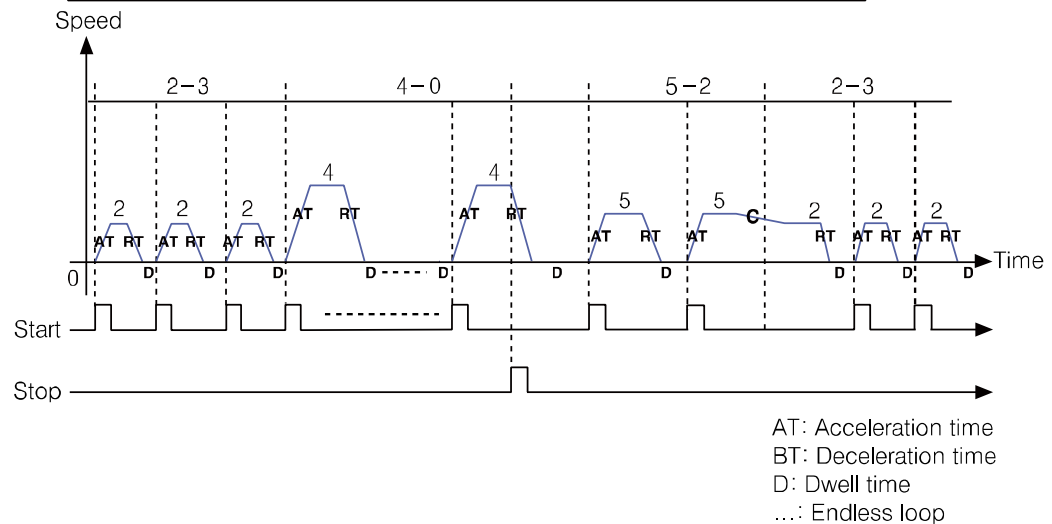

Above pattern stings has two ‘0’s which means infinite repeat.

1st Repeats #2 action list three times with single.

To start or repeat action list with single, there should be start instruction to execute the action.

2nd After repeated third #2 action list, connects #4 action list with single and repeats it infinitely (the number of repeat is 0).

3rd When #4 action list repeats infinitely, it can not execute the next action. To stop infinite repeat, executes MTSRS instruction. Therefore, #4 action list stops infinite repeat. It connects #5 action list with single and repeats it twice.

To start or repeat action list with single, there should be start instruction to execute the action.

4th 1st to 3rd steps are binded with start bracket “(” and end bracket “)” as a group action. Connects the group action 1st to 3rd steps with C(continue) and repeats it infinitely. (The number of repeat group action is “0” which means infinite repeat.)

There are three instructions to stop infinite repeat.

1) MTSRS(normal stop)

After designating special flag for stop (F401, F403), execute MTSRS(normal stop) instruction to stop infinite repeat.

With sequence information of when stopping infinite repeat, it connects the next action pattern.



Ex.

Pattern	①	②	③	④	⑤	⑥	⑦
	R(1-4R,	2-2C,	4-2)-0R,	3-4R,	2-6R

Above pattern list is the example of infinite repeat for ②, ③, ④ group action. To finish infinite repeat of this pattern list, and execute ⑥ action list, designate F401 special flag and execute MTSRS(normal stop) instruction. If infinite repeat stops at ②, it connects ⑥ action list with R. If infinite repeat stops at ③, it connects ⑥ action list with C. Or if infinite repeat stops at ④, it connects ⑥ action list with single.

2) MTSRS(normal stop)

MTSRS(normal stop) without special flag for stop executes pattern stop instruction. Infinite repeat is also one of pattern. MTSRS(normal stop) instruction is able to stop as above.

3) MTEMS(emergency stop)

It stops all operating motion instruction and error flag occurs. This is emergency stop which does not have deceleration and dwell time to stabilize. To re-execute motion instruction, execute MTEMC (removing error flag) instruction to reset error flag.

9.4.3.4 Special device and error device

(1) Special device

CH	Name	Type	R/W	Function
CH1	F100	BIT	R	Using CH1 axis <ul style="list-style-type: none"> Use: 1 Disuse: 0
	F101	BIT	R	While moving CH1 currently (one of accel, decel, constant drive) <ul style="list-style-type: none"> Moving: 1 Not moving: 0
	F102	BIT	R	Accelerating CH1 axis <ul style="list-style-type: none"> Accelerating: 1 Not accelerating: 0
	F103	BIT	R	While driving CH1 with set speed(max. speed) <ul style="list-style-type: none"> Driving with set speed: 1 Not driving with set speed: 0
	F104	BIT	R	Decelerating CH1 axis <ul style="list-style-type: none"> Decelerating: 1 Not decelerating: 0
	F105	BIT	R	Dwelling CH1 <ul style="list-style-type: none"> Dwelling: 1 Not dwelling: 0
	F106	BIT	R	Completing CH1 drive <ul style="list-style-type: none"> Completing: 1 Not completing: 0
	F107	BIT	R	Detecting S/W lower limit of CH1 axis <ul style="list-style-type: none"> Detecting S/W lower limit: 1 Not detecting S/W lower limit: 0
	F108	BIT	R	Detecting S/W upper limit of CH1 axis <ul style="list-style-type: none"> Detecting S/W upper limit: 1 Not detecting S/W upper limit: 0
	F109	BIT	R	Detecting H/W lower limit of CH1 axis <ul style="list-style-type: none"> Detecting H/W lower limit: 1 Not detecting H/W lower limit: 0
	F10A	BIT	R	Detecting H/W upper limit of CH1 <ul style="list-style-type: none"> Detecting H/W upper limit: 1 Not detecting H/W upper limit: 0
	F400	BIT	R/W	Designation flag for MTSRS(normal stop) instruction (stops action list)
	F401	BIT	R/W	Designation flag for MTSRS(normal stop) instruction (stops group list)
	F600	DWORD	R	Motion position (current position)
	F620	DWORD	R	Motion speed (current speed)
	F640	WORD	R	Motion ACT (current action number)
F650	WORD	R	Motion pattern (current pattern number)	
F660	DWORD	R	Motion base position (current origin point position)	

CH	Name	Type	R/W	Function
	F680	DWORD	R	Motion pattern speed (set speed)
CH2	F120	BIT	R	Using CH2 axis <ul style="list-style-type: none"> Use: 1 Disuse: 0
	F121	BIT	R	While moving CH2 currently (one of accel, decel, constant drive) <ul style="list-style-type: none"> Moving: 1 Not moving: 0
	F122	BIT	R	Accelerating CH2 axis <ul style="list-style-type: none"> Accelerating: 1 Not accelerating: 0
	F123	BIT	R	While driving CH2 with set speed(max. speed)_ <ul style="list-style-type: none"> Driving with set speed: 1 Not driving with set speed: 0
	F124	BIT	R	Decelerating CH2 axis <ul style="list-style-type: none"> Decelerating: 1 Not decelerating: 0
	F125	BIT	R	Dwelling CH2 <ul style="list-style-type: none"> Dwelling: 1 Not dwelling: 0
	F126	BIT	R	Completing CH2 drive <ul style="list-style-type: none"> Completing: 1 Not completing: 0
	F127	BIT	R	Detecting S/W lower limit of CH2 <ul style="list-style-type: none"> Detecting S/W lower limit: 1 Not detecting S/W lower limit: 0
	F128	BIT	R	Detecting S/W upper limit of CH2 <ul style="list-style-type: none"> Detecting S/W upper limit: 1 Not detecting S/W upper limit: 0
	F129	BIT	R	Detecting H/W lower limit of CH2 <ul style="list-style-type: none"> Detecting H/W lower limit: 1 Not detecting H/W lower limit: 0
	F12A	BIT	R	Detecting H/W upper limit of CH2 <ul style="list-style-type: none"> Detecting H/W upper limit: 1 Not detecting H/W upper limit: 0
	F402	BIT	R/W	Designation flag for MTSRS(normal stop) instruction (stops action list)
	F403	BIT	R/W	Designation flag for MTSRS(normal stop) instruction (stops group list)
	F700	DWORD	R	Motion position (current position)
	F720	DWORD	R	Motion speed (current speed)
	F740	WORD	R	Motion ACT (current action number)
	F750	WORD	R	Motion pattern (current pattern number)
	F760	DWORD	R	Motion base position (current origin point position)
F780	DWORD	R	Motion pattern speed (set speed)	

CH	Name	Type	R/W	Function
Jog	F501	BIT	R/W	CH1 jog forward drive <ul style="list-style-type: none"> ON rising: Accelerates with jog forward, and drives with constant speed OFF falling: Decelerates with jog forward, and stops
	F502	BIT	R/W	CH1 jog backward drive <ul style="list-style-type: none"> ON rising: Accelerates with jog backward, and drives with constant speed OFF falling: Decelerates with jog backward, and stops.
	F503	BIT	R/W	CH2 jog forward drive <ul style="list-style-type: none"> ON rising: Accelerates with jog forward, and drives with constant speed OFF falling: Decelerates with jog forward, and stops
	F504	BIT	R/W	CH2 jog backward drive <ul style="list-style-type: none"> ON rising: Accelerates with jog backward, and drives with constant speed OFF falling: Decelerates with jog backward, and stops.

(2) Error device

CH	Name	Error	Function
CH1	F110	CH1 error	Occurs error to CH1 during motion driving
	F11F	Emergency stop error	Error when executing MTEMS(emergency stop) instruction during motion driving
CH2	F130	CH2 error	Occurs error to CH2 during motion driving
	F13F	Emergency stop error	Error when executing MTEMS(emergency stop) instruction during motion driving

(3) Special device for error code checking

Device	GP_Device	Description
F20	UW06420	CH1 error code check
F21	UW06421	CH2 error code check

(4) Error code

Error code	Symptom	Run state	Troubleshooting
1	When inputting other starting instruction signal during using channel	Run	Clear the error by MTMEC(removing error) instruction and executes next start instruction
2	When giving progress instruction to other direction than current progressing direction during consecutive running 'C'	Stop	Edit the pattern list which has problem. Clear the error by MTMEC(removing error) instruction and executes motion operation
3	When setting position preset during running	Run	Clear the error by MTMEC(removing error) instruction
4	When there is no action list	Stop	Edit the action list which has problem.

Error code	Symptom	Run state	Troubleshooting
	to operate during executing pattern action		Clear the error by MTMEC(removing error) instruction
5	When action list type is position drive during executing pattern action and destination position is out of S/W limit range	Stop	Check and edit action list and S/W limit value which have problem. Clear the error by MTMEC(removing error) instruction
10	Excess high low limit error	Stop	Clear the error by MTMEC(removing error) instruction and escape limit with jog operation and execute the next
20	When speed parameter value is higher than maximum speed (100,000PPS) Designated pattern number of MTIDM(Indirect designated drive) instruction is out of 1 to 99	Stop	Clear the error by MTMEC(removing error) instruction and check the set parameter values

(5) I/O device

CH	Device	Function
CH1	X0	CH1 upper limit input device
	X1	CH1 lower limit input device
	X2	CH1 origin point input device
	Y0	CH1 PWM output device
	Y2	CH1 directional selection output device
CH2	X3	CH2 upper limit input device
	X4	CH2 lower limit input device
	X5	CH2 origin point input device
	Y1	CH2 PWM output device
	Y3	CH2 directional selection output device

9.4.3.5 Motion Instruction

9.4.3.5.1. MTVDM: speed direct drive instruction

You can designate direct drive data(drive speed, drive direction, etc) directly and it executes speed drive.

(1) Instruction

MTVDM	S0	S1	S2	S3	S4	S5
-------	----	----	----	----	----	----

(2) Operand

Operand	Type	Description	Available range
S0	WORD	CH(axis) to execute instruction	CH1 or CH2
S1	BIT	Drive direction to decide position	Forward(1), backward(0)
S2	DWORD	Drive speed to decide position	1 to 100,000pps
S3	WORD	Dwell time	0 to 65535ms
S4	WORD	Acceleration time	Acceleration time 1 to 5 of common configuration
S5	WORD	Deceleration time	Deceleration time 1 to 5 of common configuration

Operand	Device														
	X	Y	M	S	D	T	C	Z	F	V	L	R	UW	UB	Integer
S0	<input type="radio"/>	-	<input type="radio"/>	-	<input type="radio"/>	-	-	<input type="radio"/>	-	-	-	-	<input type="radio"/>	-	<input type="radio"/>
S1	<input type="radio"/>	-	<input type="radio"/>	-	-	-	-	<input type="radio"/>	-	-	-	-	-	<input type="radio"/>	-
S2	<input type="radio"/>	-	<input type="radio"/>	-	<input type="radio"/>	-	-	<input type="radio"/>	-	-	-	-	<input type="radio"/>	-	<input type="radio"/>
S3	<input type="radio"/>	-	<input type="radio"/>	-	<input type="radio"/>	-	-	<input type="radio"/>	-	-	-	-	<input type="radio"/>	-	<input type="radio"/>
S4	<input type="radio"/>	-	<input type="radio"/>	-	<input type="radio"/>	-	-	<input type="radio"/>	-	-	-	-	<input type="radio"/>	-	<input type="radio"/>
S5	<input type="radio"/>	-	<input type="radio"/>	-	<input type="radio"/>	-	-	<input type="radio"/>	-	-	-	-	<input type="radio"/>	-	<input type="radio"/>



Note

- Be sure that if set drive speed is over than max. speed (100,000pps), it may cause malfunction.
- Acceleration/Deceleration time is one of Acceleration/Deceleration time 1 to 5 of 'Common Configuration' at [Workspace]-[Parameter]-[MOTION] in SmartStudio.
- If set drive speed is lower than start speed, this set drive speed drives constant without acceleration/deceleration drive.

(3) Ladder and mnemonic

▪ Ladder

Program(New Project*)			Channel	Drv direction	Drv speed	Dwell time	Accel time	Decel time
0	M00000	MTVDM	M0100	M00105	M0110	M0115	M0120	M0125
11								END

▪ Mnemonic

Program(New Project*)										
Step	Instruction	OP1	OP2	OP3	OP4	OP5	OP6	OP7	OP8	OP9
0	LOADP	M00000								
2	MTVDM	M0100	M00105	M0110	M0115	M0120	M0125			
11	END									

**Note**

Please use the device that matches the size of each operand.

(4) Function

- Executes speed direct drive at rising edge of input condition.
- Drives set speed and direction until executing stop sign.
- This instruction is able to set only drive data items. Basic drive data(start speed, acceleration time, deceleration time, etc) is the set value of 'Common Configuration' at [Workspace]-[Parameter]-[MOTION] in SmartStudio.

**Caution**

[Caution for common configuration]

- To use motion instruction, please designate the appropriate CH whether to use or not.
- Please set acceleration/deceleration time appropriately by drive speed. If you set acceleration/deceleration time is too short or too long, it may cause malfunction.
- If set start speed is higher than starting frequency of motor, it may cause malfunction.

(5) Example of usage

“Speed drive with 10000 speed.”

- 1) ‘MOTION’ tab

Designate ‘Common Configuration’ at [Workspace]-[Parameter]-[MOTION] in SmartStudio as below figure.

Common Configuration		
<input type="checkbox"/> Using Internal Device	Device	
Item	Ch1 Axis	Ch2 Axis
Ⓐ Enable Ch	TRUE	FALSE
S/W Upper Limit	2147483647	2147483647
S/W Lower Limit	-2147483647	-2147483647
Ⓐ Start Speed(pps)	1000	0
Origin Point	0	0
Ⓑ Home Search Direction	Forward	Forward
Ⓐ Acceleration Time1(ms)	1000	0
Acceleration Time2(ms)	0	0
Acceleration Time3(ms)	0	0
Acceleration Time4(ms)	0	0
Acceleration Time5(ms)	0	0
Ⓐ Deceleration Time1(ms)	1000	0
Deceleration Time2(ms)	0	0
Deceleration Time3(ms)	0	0
Deceleration Time4(ms)	0	0
Deceleration Time5(ms)	0	0
Jog Speed(pps)	0	0
Jog Acceleration Time(ms)	0	0
Jog Deceleration Time(ms)	0	0
Acceleration Time to Origin(ms)	1000	0
Ⓑ Deceleration Time to Origin(ms)	1000	0
Home Search Speed(pps)	5000	0
Enable S/W Limit	TRUE	FALSE
Enable H/W Limit	TRUE	FALSE
Ⓑ Origin Back Kind	H/W	H/W

Ⓐ: drive data, Ⓑ: origin back data

For further details of each setting value, refer to ‘9.4.3.2 Motion setting parameter’.

This example is set enable ch, s/w upper/lower limit, start speed, origin point, home search direction, acceleration time, deceleration time, acceleration time to origin, deceleration time to origin, home search speed, enable S/W limit, enable H/W limit, and origin back kind.

2) PLC program

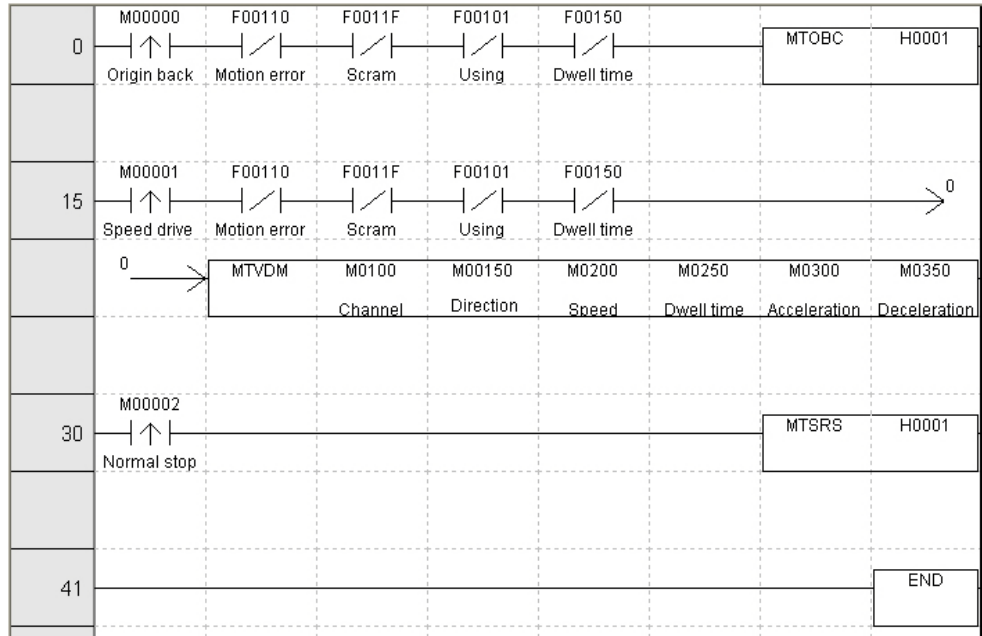

3) Drive description

This example is programmed to speed direct drive by user's input after origin back. The device of MTVDM(speed direct drive) is as following.

Device	Value	Description
M100	1	Using CH
M150	1	Drive direction(0: backward 1: forward)
M200	10000	Drive speed
M250	1000	Dwell time
M300	1	Acceleration time
M350	1	Deceleration time



Note

- Acceleration/Deceleration time is one of Acceleration/Deceleration time 1 to 5 of 'Common Configuration' at [Workspace]-[Parameter]-[MOTION] in SmartStudio. The other time setting is not supported.
- Basic drive data (start speed, acceleration time, deceleration time, etc) is the set value of 'Common Configuration' at [Workspace]-[Parameter]-[MOTION] in SmartStudio.

- 1st When rising edge occurs at M0 device, executes MTOBC(origin back) instruction. MTOBC(origin back) instruction searches origin point by origin back kind of 'Common Configuration' (This example is set as H/W.)
- 2nd When rising edge occurs at M1 device, executes MTVDM (speed direct drive) instruction.
- 3rd When executeing MTVDM(speed direct drive) instruction, accelerates up to the set drive speed during acceleration time and drives constant with the set drive speed.
- 4th MTVDM(speed direct drive) instruction is speed drive. It drives continuously until MTSRS(normal stop) instruction occurs. MTVDM(speed direct drive) instruction is able to stop by MTSRS(normal stop), MTEMS(emergency stop) instructions.

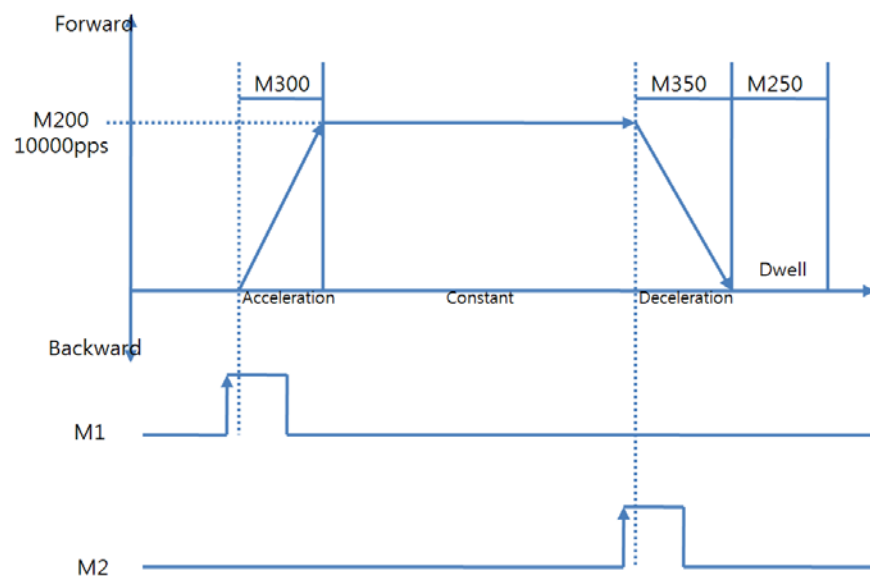

9.4.3.5.2. MTPDM: position direct drive instruction

You can designate direct drive data(drive speed, drive direction, etc) directly and it executes position drive.

(1) Instruction

MTPDM	S0	S1	S2	S3	S4	S5
--------------	-----------	-----------	-----------	-----------	-----------	-----------

(2) Operand

Operand	Type	Description	Available range
S0	WORD	CH(axis) to execute instruction	CH1 or CH2
S1	DWORD	Destination position to decide position	-2,147,483,648 to 2,147483,647
S2	DWORD	Drive speed to decide position	1 to 100,000pps
S3	WORD	Dwell time	0 to 65535ms
S4	WORD	Acceleration time	Acceleration time 1 to 5 of common configuration
S5	WORD	Deceleration time	Deceleration time 1 to 5 of common configuration

Oper and	Device														
	X	Y	M	S	D	T	C	Z	F	V	L	R	UW	UB	Integer
S0	○	-	○	-	○	-	-	○	-	-	-	-	○	-	○
S1	○	-	○	-	○	-	-	○	-	-	-	-	○	-	○
S2	○	-	○	-	○	-	-	○	-	-	-	-	○	-	○
S3	○	-	○	-	○	-	-	○	-	-	-	-	○	-	○
S4	○	-	○	-	○	-	-	○	-	-	-	-	○	-	○
S5	○	-	○	-	○	-	-	○	-	-	-	-	○	-	○

**Caution**

- Be sure that if set drive speed is over than max. speed (100,000pps), it may cause malfunction.
- Acceleration/Deceleration time is one of Acceleration/Deceleration time 1 to 5 of 'Common Configuration' at [Workspace]-[Parameter]-[MOTION] in SmartStudio.
- If set drive speed is lower than start speed, this set drive speed drives constant without acceleration/deceleration drive.
- The range of destination position value is from -2,147,483,648 to 2,147483,647.

(3) Ladder and mnemonic

- Ladder

Program(New Project*)			Channel	Dst position	Drv speed	Dwell time	Accel time	Decel time
0	M00000	MTPDM	M0100	M0115	M0120	M0125	M0130	M0135
11								END

- Mnemonic

Program(New Project*)										
Step	Instruction	OP1	OP2	OP3	OP4	OP5	OP6	OP7	OP8	OP9
0	LOADP	M00000								
2	MTPDM	M0100	M0115	M0120	M0125	M0130	M0135			
11	END									

**Note**

- Please use the device that matches the size of each operand.
- Moving position by position direct drive instruction supports only absolute coordination. For moving relative coordination, please action list.

(4) Function

- Executes position direct drive at rising edge of input condition.
- When arriving set destination position, it decelerates and stops the drive.
- This instruction is able to set only drive data items. Basic drive data(start speed, acceleration time, deceleration time, etc) is the set value of 'Common Configuration' at [Workspace]-[Parameter]-[MOTION] in SmartStudio.

**Caution**

[Caution for common configuration]

- To use motion instruction, please designate the appropriate CH whether to use or not.
- Please set acceleration/deceleration time appropriately by drive speed. If you set acceleration/deceleration time is too short or too long, it may cause malfunction.
- If set start speed is higher than starting frequency of motor, it may cause malfunction.

(5) Example of usage

“Moves position from current position to 50000 position.”

1) ‘MOTION’ tab

Designate ‘Common Configuration’ at [Workspace]-[Parameter]-[MOTION] in SmartStudio as below figure.

Item	Ch1 Axis	Ch2 Axis
(a) Enable Ch	TRUE	FALSE
S/W Upper Limit	2147483647	2147483647
S/W Lower Limit	-2147483647	-2147483647
(a) Start Speed(pps)	1000	0
Orgin Point	0	0
(b) Home Search Direction	Forward	Forward
(a) Acceleration Time1(ms)	1000	0
Acceleration Time2(ms)	0	0
Acceleration Time3(ms)	0	0
Acceleration Time4(ms)	0	0
Acceleration Time5(ms)	0	0
(a) Deceleration Time1(ms)	1000	0
Deceleration Time2(ms)	0	0
Deceleration Time3(ms)	0	0
Deceleration Time4(ms)	0	0
Deceleration Time5(ms)	0	0
Jog Speed(pps)	0	0
Jog Acceleration Time(ms)	0	0
Jog Deceleration Time(ms)	0	0
Acceleration Time to Orgin(ms)	1000	0
(b) Deceleration Time to Orgin(ms)	1000	0
Home Search Speed(pps)	5000	0
Enable S/W Limit	TRUE	FALSE
Enable H/W Limit	TRUE	FALSE
(b) Origin Back Kind	H/W	H/W

(a): drive data, (b): origin back data

For further details of each setting value, refer to “9.4.3.2 Motion setting parameter”.

This example is set enable ch, s/w upper/lower limit, start speed, origin point, home search direction, acceleration time, deceleration time, acceleration time to origin, deceleration time to origin, home search speed, enable S/W limit, enable H/W limit, and origin back kind.

2) PLC program

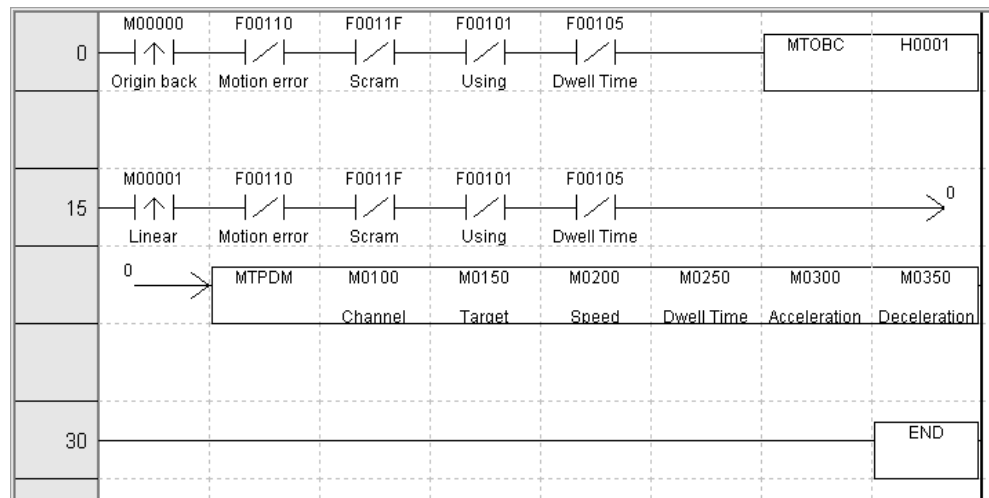

3) Drive description

This example is programmed to position direct drive by user's input after origin back. The device of MTPDM(position direct drive) is as following.

Device	Value	Description
M100	1	Using CH
M150	50000	Destination position
M200	10000	Drive speed
M250	1000	Dwell time
M300	1	Acceleration time
M350	1	Deceleration time



Note

- Acceleration/Deceleration time is one of Acceleration/Deceleration time 1 to 5 of 'Common Configuration' at [Workspace]-[Parameter]-[MOTION] in SmartStudio. The other time setting is not supported.
- Basic drive data (start speed, acceleration time, deceleration time, etc) is the set value of 'Common Configuration' at [Workspace]-[Parameter]-[MOTION] in SmartStudio.

- 1st When rising edge occurs at M0 device, executes MTOBC (origin back) instruction. MTOBC(origin back) instruction searches origin point by origin back kind of 'Common Configuration' (This example is set as H/W.)
- 2nd When rising edge at M1 device, executes MTPDM(position direct drive) instruction .
- 3rd When executing MTPDM(position direct drive) instruction, accelerates up to the set drive speed during acceleration time and drives constant with the set drive speed.
- 4th Decelerates during deceleration time and stops at the set destination position.

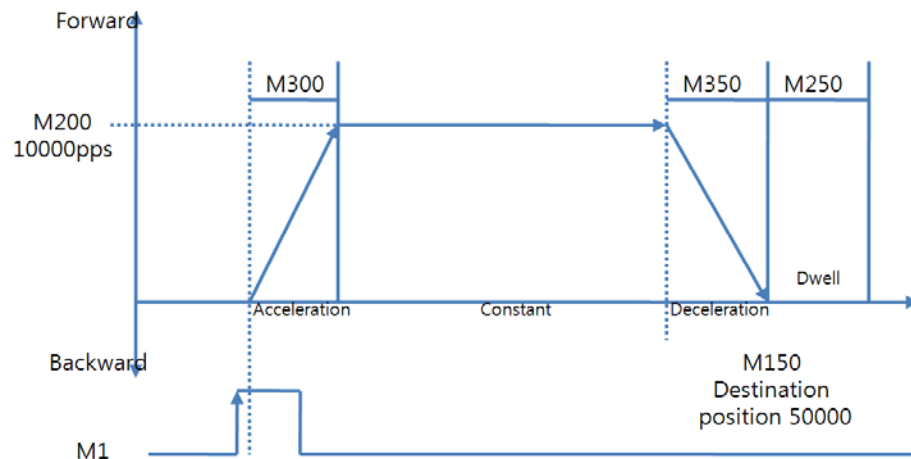

9.4.3.5.3. MTIDM: Indirect designate drive instruction

You can designate pattern list number and operates motion.

(1) Instruction

MTIDM	S0	S1
-------	----	----

(2) Operand

Operand	Type	Description	Available range
S0	WORD	CH(axis) to execute instruction	CH1 or CH2
S1	WORD	Number of pattern list	1 to 99

Oper and	Device														
	X	Y	M	S	D	T	C	Z	F	V	L	R	UW	UB	Integer
S0	<input type="radio"/>	-	<input type="radio"/>	-	<input type="radio"/>	-	-	<input type="radio"/>	-	-	-	-	<input type="radio"/>	-	<input type="radio"/>
S1	<input type="radio"/>	-	<input type="radio"/>	-	<input type="radio"/>	-	-	<input type="radio"/>	-	-	-	-	<input type="radio"/>	-	<input type="radio"/>



Note

- You cannot over pattern list range from 1 to 99.
- Designated pattern list should have one more action list.
- For pattern list writing, refer to “9.4.3.3 Pattern writing”.

(3) Ladder and mnemonic

- Ladder

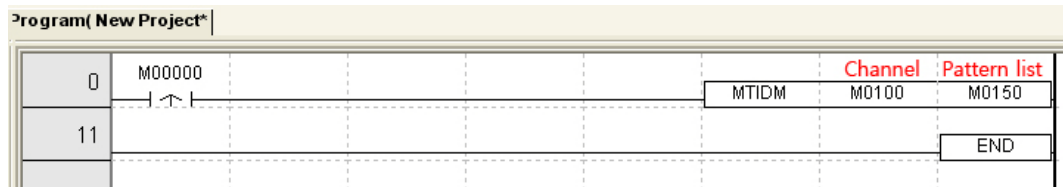

- Mnemonic

Step	Instruction	OP1	OP2	OP3	OP4	OP5	OP6	OP7	OP8	OP9
0	LOADP	M00000								
2	MTIDM	M0100	M0150							
11	END									



Note

Please use the device that matches the size of each operand.

(4) Stop

- ① There are other stop result by MTSRS(stop instruction) or by special flag.
 - MTSRS(normal stop): normal stop
Completes executing action of action list and finishes the pattern.
 - MTSRS(normal stop)+ special flag (F400 or F402) : action list stop
To execute next actionlist or group during executing pattern, use this instructions. If executing pattern is speed drive, this combination instructions stops speed drive and executes next action list.

- MTSRS(normal stop)+ special flag(F401 or F403) : group stop
Stops the pattern which is executing as group type and executes the next action list or group.

- ② MTEMS (emergency stop) : emergency stop
Executes emergency stop to action list which is executing as pattern drive.



Caution

MTEMS (emergency stop) instruction is emergency stop without deceleration and dwell time. It may cause malfunction to motor. If it is not emergency, please use MTSRS(normal stop) instruction to stop normally.

(5) Function

- Executes indirect designate drive at rising edge of input condition.
- It is able to execute user-defined patterns.

(6) Example of usage

“Loads and executes the saved pattern at pattern list 1.”

MTIDM(indirect designate drive) instruction executes the designated pattern list number. It should be write pattern list. To write pattern list, common configuration, action list should be set.

- 1) 'MOTION' tab

Designate 'Common Configuration', 'Action list', and 'Pattern list' at [Workspace]-[Parameter]-[MOTION] in SmartStudio as below figure.

① Common configuration

Item	Ch1 Axis	Ch2 Axis
a Enable Ch	TRUE	FALSE
S/W Upper Limit	2147483647	2147483647
S/W Lower Limit	-2147483647	-2147483647
a Start Speed(pps)	1000	0
Orgin Point	0	0
b Home Search Direction	Forward	Forward
a Acceleration Time1(ms)	1000	0
Acceleration Time2(ms)	0	0
Acceleration Time3(ms)	0	0
Acceleration Time4(ms)	0	0
Acceleration Time5(ms)	0	0
a Deceleration Time1(ms)	1000	0
Deceleration Time2(ms)	0	0
Deceleration Time3(ms)	0	0
Deceleration Time4(ms)	0	0
Deceleration Time5(ms)	0	0
Jog Speed(pps)	0	0
Jog Acceleration Time(ms)	0	0
Jog Deceleration Time(ms)	0	0
Acceleration Time to Orgin(ms)	1000	0
b Deceleration Time to Orgin(ms)	1000	0
Home Search Speed(pps)	5000	0
Enable S/W Limit	TRUE	FALSE
Enable H/W Limit	TRUE	FALSE
b Origin Back Kind	H/W	H/W

a: drive data, **b**: origin back data

② Action list

Num	Drv Type	Coodi Type	Dst Pos	Drv Direction	Drv Speed(pps)	Accel Time	Decel Time	Dwell Time(ms)
1	Position	Relative	50000	Forward	5000	1	1	500
2	Speed	Absolute	0	Forward	10000	1	1	1000
3	Position	Absolute	0	Forward	0	1	1	0
4	Position	Absolute	0	Forward	0	1	1	0

③ Pattern list

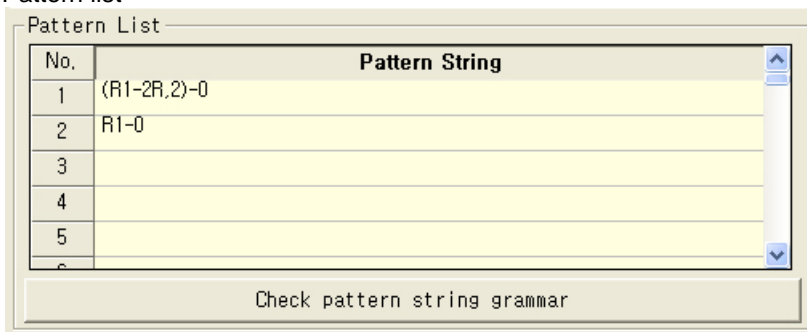

For pattern list writing, refer to “9.4.3.3 Pattern writing”.

2) PLC program

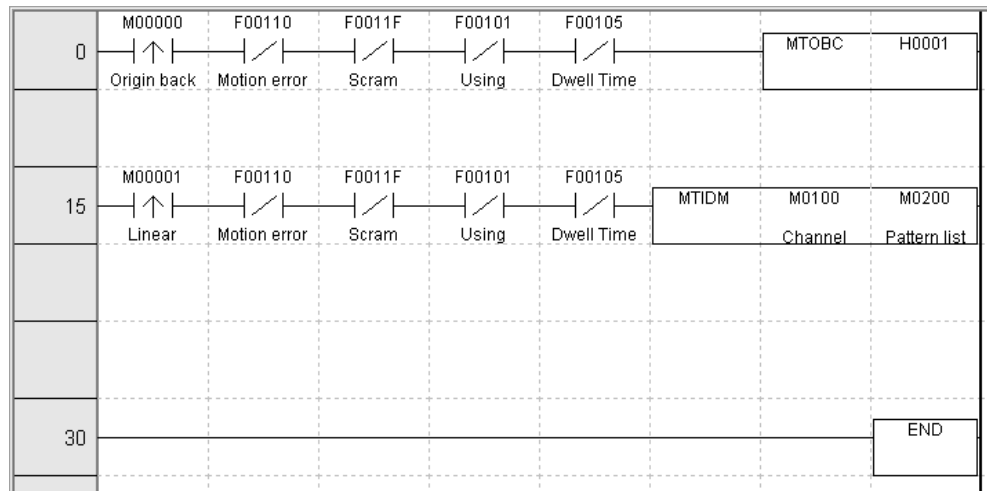

3) Drive description

This example is programmed to position direct drive by user’s input at pattern list after origin back. The device of MTIDM(indirect designate drive) is as following.

Device	Value	Description
M100	1	Using CH
M200	1	Pattern list



Note

- Check there is value of designated pattern list.
- Check there is action list value of designated pattern list contents.

- 1st When rising edge occurs at M0 device, executes MTOBC (origin back) instruction.
MTOBC(origin back) instruction searches origin point by origin back kind of
'Common Configuration' (This example is set as H/W.)
- 2nd When rising edge occurs at M1 device, executes MTIDM(indirect designate drive)
instruction.

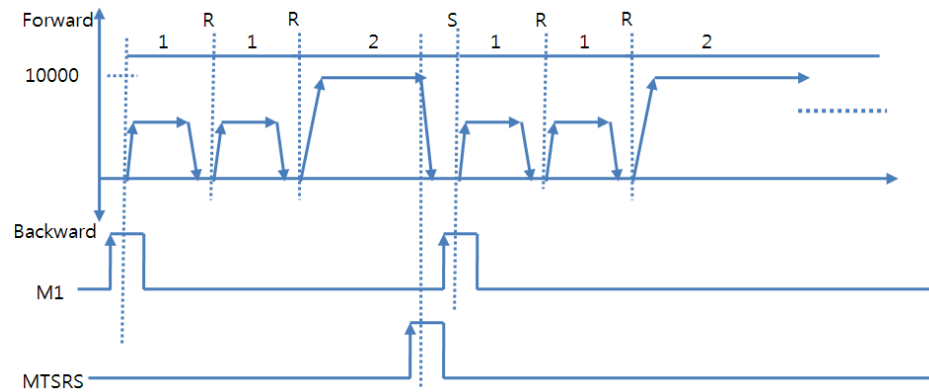

Note

MTSRS(normal stop) instruction in pattern list is available for pattern complete, action list complete, group complete.

**Note**

- Please use the device that matches the size of each operand.
- Action list is available only when drive type is position drive.

(4) Stop

- ① MTSRS : normal stop
Executes normal stop to two axis which are line driving at the same time.
- ② MTEMS : emergency stop
Executes emergency stop to two axis which are line driving at the same time.

(5) Function

- Executes line interpolation drive at rising edge of input condition.
- It drives for the moving distance of two axes to line from current stop position to destination position with CH1, CH2 axes.
- The decision of main axis and sub axis is by movement distance. The axis which is more distance than the other is set as main axis. If each distance of two axes is same, CH1 becomes main axis.
- The speed of main axis does not refer to drive parameter's value. The below operation formula helps to decide drive speed, acceleration time, and deceleration time and it executes the drive.

$$\text{Sub axis speed} = \frac{\text{Main axis speed} \times \text{Sub axis destination position}}{\text{Main axis destination position}}$$

**Caution**

- Be sure that two axes stop at the same time when stopping drive.
- MTEMS(emergency stop) instruction is emergency stop without deceleration and dwell time. It may cause malfunction to motor. If it is not emergency, please use MTSRS(normal stop) instruction to stop normally.

(6) Example of usage

“Executes line interpolation drive with action list 1 and action list 2.”

1) ‘MOTION’ tab

Designate ‘Common Configuration’, ‘Action list’ at [Workspace]-[Parameter]-[MOTION] in SmartStudio as below figure.

① Common configuration

Item	Ch1 Axis	Ch2 Axis
a Enable Ch	TRUE	TRUE
S/W Upper Limit	2147483647	2147483647
S/W Lower Limit	-2147483647	-2147483647
a Start Speed(pps)	1000	1000
Orgin Point	0	0
b Home Search Direction	Forward	Forward
a Acceleration Time1(ms)	1000	1000
Acceleration Time2(ms)	0	0
Acceleration Time3(ms)	0	0
Acceleration Time4(ms)	0	0
Acceleration Time5(ms)	0	0
a Deceleration Time1(ms)	1000	1000
Deceleration Time2(ms)	0	0
Deceleration Time3(ms)	0	0
Deceleration Time4(ms)	0	0
Deceleration Time5(ms)	0	0
Jog Speed(pps)	0	0
Jog Acceleration Time(ms)	0	0
Jog Deceleration Time(ms)	0	0
Acceleration Time to Orgin(ms)	1000	1000
b Deceleration Time to Orgin(ms)	1000	1000
Home Search Speed(pps)	5000	5000
Enable S/W Limit	TRUE	FALSE
Enable H/W Limit	TRUE	FALSE
b Origin Back Kind	H/W	H/W

a: drive data, **b**: origin back data

② Action list

Num	Drv Type	Coodi Type	Dst Pos	Drv Direction	Drv Speed(pps)	Accel Time	Decel Time	Dwell Time(ms)
1	Position	Relative	50000	Forward	5000	1	1	500
2	Position	Absolute	30000	Forward	10000	1	1	1000
3	Position	Absolute	0	Forward	0	1	1	0

2) PLC program

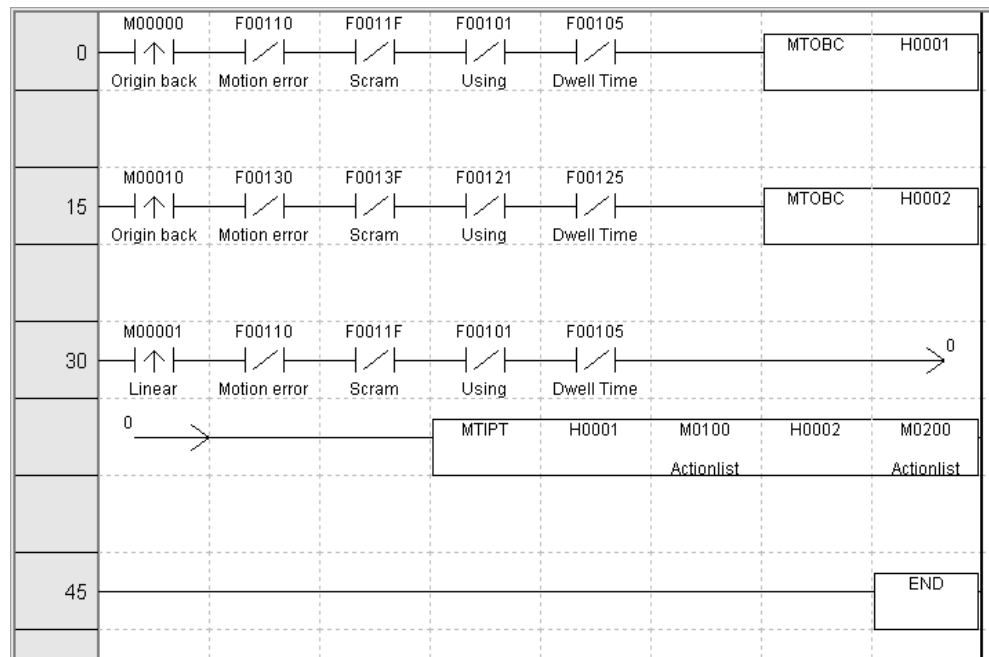

3) Drive description

- 1st When rising edge occurs at M0 device, executes MTOBC (origin back) instruction. MTOBC(origin back) instruction searches origin point by origin back kind of 'Common Configuration' (This example is set as H/W.)
- 2nd When rising edge at M10 device, executes MTOBC(origin back) instruction. MTOBC(origin back) instruction searches origin point by origin back kind of 'Common Configuration' (This example is set as H/W.)
- 3rd When rising edge at M1 device, executes MTIPT(line interpolation) instruction. At line interpolation drive, the CH1 axis which is more distance than the other CH2 is set as main axis. In this case, CH2 sub axis's drive data is ignored and it has the drive data by the below formula.

$$3000 = \frac{5000 \times 30000}{50000}$$

Therefore, main axis speed is 5000 in this example and sub axis speed is 3000 by above formula.

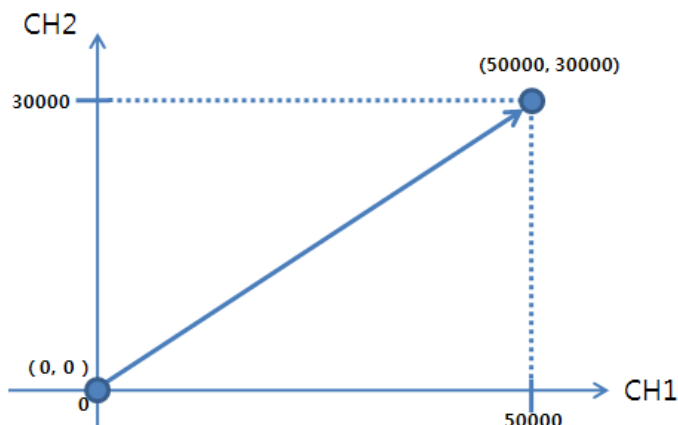

9.4.3.5.5. MTUAI: action list drive instruction

You can designate action list number to execute motion.

(1) Instruction

MTUAI	S0	S1
-------	----	----

(2) Operand

Operand	Type	Description	Available range
S0	WORD	CH(axis) to execute instruction	CH1 or CH2
S1	WORD	Number of action list	1 to 99

Oper and	Device														
	X	Y	M	S	D	T	C	Z	F	V	L	R	UW	UB	Integer
S0	<input type="radio"/>	-	<input type="radio"/>	-	<input type="radio"/>	-	-	<input type="radio"/>	-	-	-	-	<input type="radio"/>	-	<input type="radio"/>
S1	<input type="radio"/>	-	<input type="radio"/>	-	<input type="radio"/>	-	-	<input type="radio"/>	-	-	-	-	<input type="radio"/>	-	<input type="radio"/>



Note

- You cannot over pattern list range from 1 to 99.
- You cannot use the action list which does not have any contents.

(3) Ladder and mnemonic

- Ladder

Program(New Project*		
0	M00000	Channel Action list MTUAI M0100 M0150
11		END

- Mnemonic

Program(New Project*										
Step	Instruction	OP1	OP2	OP3	OP4	OP5	OP6	OP7	OP8	OP9
0	LOADP	M00000								
2	MTUAI	M0100	M0150							
11	END									



Note

Please use the device that matches the size of each operand.

(4) Function

- Executes action list drive at rising edge of input condition.
- Executes user-defined action list.

(5) Example of usage

“Executes action list 1.”

MTUAI(action list drive) instruction executes the designated action list number. You should write action list. To write action list, you should designate ‘Common Configuration’ at first.

- 1) ‘MOTION’ tab

Designate ‘Common Configuration’, and ‘Action list’ at [Workspace]-[Parameter]-[MOTION] in SmartStudio as below figure.

① Common configuration

Item	Ch1 Axis	Ch2 Axis
a Enable Ch	TRUE	FALSE
S/W Upper Limit	2147483647	2147483647
S/W Lower Limit	-2147483647	-2147483647
a Start Speed(pps)	1000	0
Orgin Point	0	0
b Home Search Direction	Forward	Forward
a Acceleration Time1(ms)	1000	0
Acceleration Time2(ms)	0	0
Acceleration Time3(ms)	0	0
Acceleration Time4(ms)	0	0
Acceleration Time5(ms)	0	0
a Deceleration Time1(ms)	1000	0
Deceleration Time2(ms)	0	0
Deceleration Time3(ms)	0	0
Deceleration Time4(ms)	0	0
Deceleration Time5(ms)	0	0
Jog Speed(pps)	0	0
Jog Acceleration Time(ms)	0	0
Jog Deceleration Time(ms)	0	0
Acceleration Time to Orgin(ms)	1000	0
b Deceleration Time to Orgin(ms)	1000	0
Home Search Speed(pps)	5000	0
Enable S/W Limit	TRUE	FALSE
Enable H/W Limit	TRUE	FALSE
b Origin Back Kind	H/W	H/W

a: drive data, **b**: origin back data

② Action list

Num	Drv Type	Coodi Type	Dst Pos	Drv Direction	Drv Speed(pps)	Accel Time	Decel Time	Dwell Time(m)
1	Position	Relative	50000	Forward	5000	1	1	500
2	Speed	Absolute	0	Forward	10000	1	1	1000
3	Position	Absolute	0	Forward	0	1	1	0

There are two type of action list; position, or speed drive.

2) PLC program

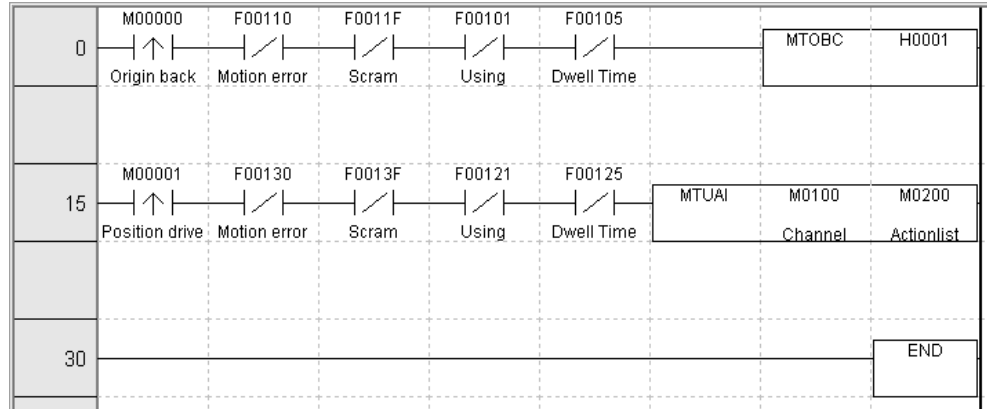

3) Drive description

This example is programmed to action list drive by user's input after origin back. The device of MTUAI(action list drive) is as following.

Device	Value	Description
M100	1	Using CH
M200	1	Action list



Note

- Action list range is from 1 to 99.
- There should be designated action list value before executing action list drive instruction.

1st When rising edge occurs at M0 device, executes MTOBC (origin back) instruction. MTOBC(origin back) instruction searches origin point by origin back kind of 'Common Configuration' (This example is set as H/W.)

2nd When rising edge occurs at M1 device, executes MTUAI(action list drive) instruction. MTUAI(action list drive) uses CH1 by operand setting value and executes action list

1.

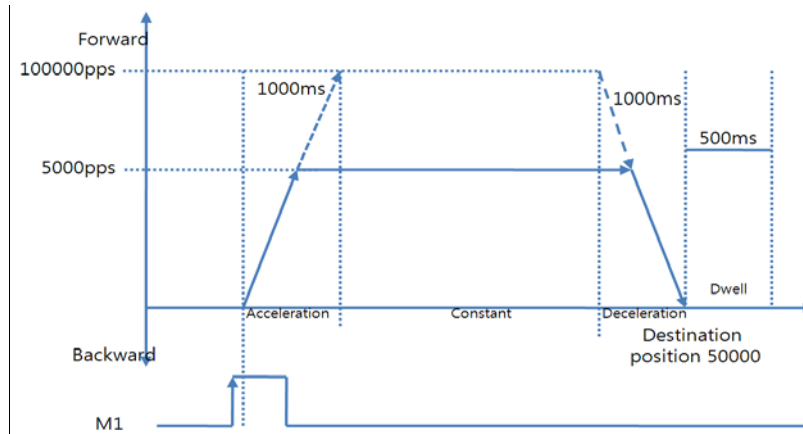

Note

- You cannot use the action list which does not have any contents.
- Position drive of action list has two types; absolute or relative. Be sure to use this properly.

9.4.3.5.6. MTMEC: error remove instruction

This instruction clears error flag during motion drive.

(1) Instruction

MTMEC	S0
-------	----

(2) Operand

Operand	Type	Description	Available range
S0	WORD	CH(axis) to execute instruction	CH1 or CH2

Oper and	Device														
	X	Y	M	S	D	T	C	Z	F	V	L	R	UW	UB	Integer
S0	<input type="radio"/>	-	<input type="radio"/>	-	<input type="radio"/>	-	-	<input type="radio"/>	-	-	-	-	<input type="radio"/>	-	<input type="radio"/>

(3) Ladder and mnemonic

▪ Ladder

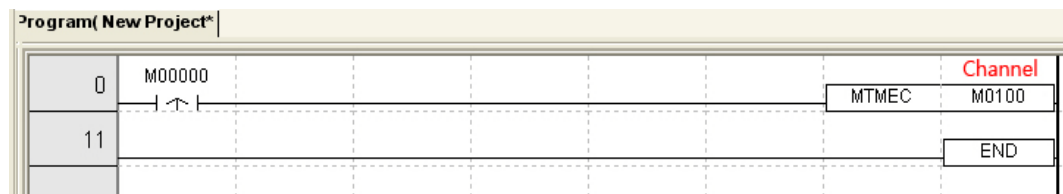

▪ Mnemonic

Step	Instruction	OP1	OP2	OP3	OP4	OP5	OP6	OP7	OP8	OP9
0	LOADP	M00000								
2	MTMEC	M0100								
11	END									

(4) Function

- Executes error remove instruction at rising edge of input condition.
- Clears errors of user-defined CH.

9.4.3.5.7. MTEMS: emergency stop instruction

If there is emergency situation during motion drive, executes emergency stop to stop all actions related with motion.

(1) Instruction

MTEMS	S0
--------------	-----------

(2) Operand

Operand	Type	Description	Available range
S0	WORD	CH(axis) to execute instruction	CH1 or CH2

Oper and	Device														
	X	Y	M	S	D	T	C	Z	F	V	L	R	UW	UB	Integer
S0	<input type="radio"/>	-	<input type="radio"/>	-	<input type="radio"/>	-	-	<input type="radio"/>	-	-	-	-	<input type="radio"/>	-	<input type="radio"/>

(3) Ladder and mnemonic

- Ladder

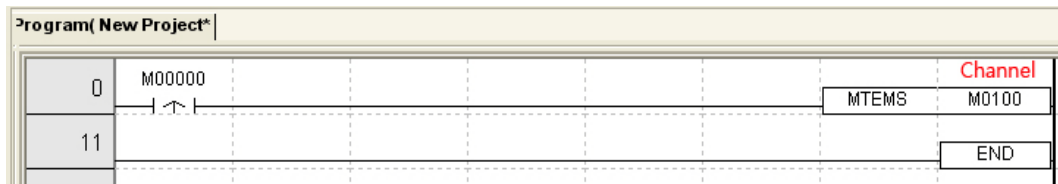

- Mnemonic

Step	Instruction	OP1	OP2	OP3	OP4	OP5	OP6	OP7	OP8	OP9
0	LOADP	M00000								
2	MTEMS	M0100								
11	END									

(4) Function

- Executes emergency stop instruction at rising edge of input condition.
- All motion actions of user-defined CH stops urgently.
- Emergency stop flag of user-defined CH is activated.
- Error designated CH is able to clear by MTMEC(error remove) instruction.



Caution

MTEMS(emergency stop) instruction is emergency stop without deceleration and dwell time. It may cause malfunction to motor.

9.4.3.5.8. MTCPP: current position preset instruction

It does not mechanical move and changes saved current position to set position.

(1) Instruction

MTCPP	S0	S1
-------	----	----

(2) Operand

Operand	Type	Description	Available range
S0	WORD	CH(axis) to execute instruction	CH1 or CH2
S1	DWORD	To be changed position value	-2,147,483,648 to 2,147,483,647

Oper and	Device														
	X	Y	M	S	D	T	C	Z	F	V	L	R	UW	UB	Integer
S0	<input type="radio"/>	-	<input type="radio"/>	-	<input type="radio"/>	-	-	<input type="radio"/>	-	-	-	-	<input type="radio"/>	-	<input type="radio"/>
S1	<input type="radio"/>	-	<input type="radio"/>	-	<input type="radio"/>	-	-	<input type="radio"/>	-	-	-	-	<input type="radio"/>	-	<input type="radio"/>



Note

If using S/W limit, you cannot set current position preset value by over S/W limit value.

(3) Ladder and mnemonic

- Ladder

Program(New Project*)			Channel	Changed position
0	M00000	MTCPP	M0050	M0100
11				END

- Mnemonic

Program(New Project*)										
Step	Instruction	OP1	OP2	OP3	OP4	OP5	OP6	OP7	OP8	OP9
0	LOADP	M00000								
2	MTCPP	M0050	M0100							
11	END									



Note

Please use the device that matches the size of each operand.

(4) Function

- Executes current position preset instruction at rising edge of input condition.
- Changes current position to user-defined set position.



Note

If you set current position preset during motion driving, this instruction does not operate.

9.4.3.5.10.MTSRS: normal stop instruction

Executes normal stop instruction to currently motion driving CH

(1) Instruction

MTSRS	S0
-------	----

(2) Operand

Operand	Type	Description	Available range
S0	WORD	CH(axis) to execute instruction	CH1 or CH2

Oper and	Device														
	X	Y	M	S	D	T	C	Z	F	V	L	R	UW	UB	Integer
S0	<input type="radio"/>	-	<input type="radio"/>	-	<input type="radio"/>	-	-	<input type="radio"/>	-	-	-	-	<input type="radio"/>	-	<input type="radio"/>

(3) Ladder and mnemonic

▪ Ladder

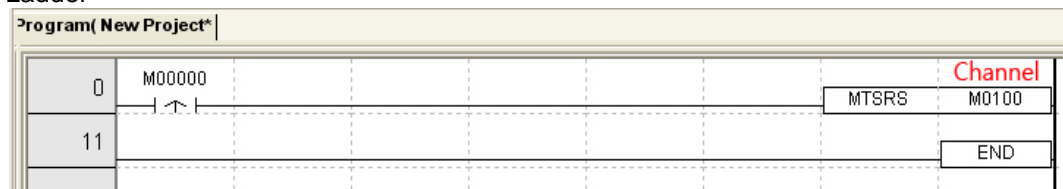

▪ Mnemonic

Step	Instruction	OP1	OP2	OP3	OP4	OP5	OP6	OP7	OP8
0	LOADP	M00000							
2	MTSRS	M0100							
11	END								

(4) Function

- Executes normal stop instruction at rising edge of input condition.
- Normal stop gives stop sign to appropriate CH with deceleration, stop, dwell time for currently motion driving as basic stop method.
- In MTIDM(indirect designate drive) instruction, MTSRS(normal stop) instruction and special flag execute as following.
 - ① MTSRS(normal stop): normal stop
Completes executing action of action list and finishes the pattern.
 - ② MTSRS(normal stop)+ special flag (F400 or F402) : action list stop
To execute next actionlist or group during executing pattern, use this instructions. If executing pattern is speed drive, this combination instructions stops speed drive and executes next action list.
 - ③ normal stop)+ special flag(F401 or F403) : group stop
Stops the pattern which is executing as group type and executes the next action list or group.

9.4.3.5.11.MTOBC: origin back instruction

Before executing motion action, designates action position as origin point or returns back the set origin point during motion driving.

(1) Instruction

MTOBC	S0
--------------	-----------

(2) Operand

Operand	Type	Description	Available range
S0	WORD	CH(axis) to execute instruction	CH1 or CH2

Oper and	Device														
	X	Y	M	S	D	T	C	Z	F	V	L	R	UW	UB	Integer
S0	<input type="radio"/>	-	<input type="radio"/>	-	<input type="radio"/>	-	-	<input type="radio"/>	-	-	-	-	<input type="radio"/>	-	<input type="radio"/>

(3) Ladder and mnemonic

▪ Ladder

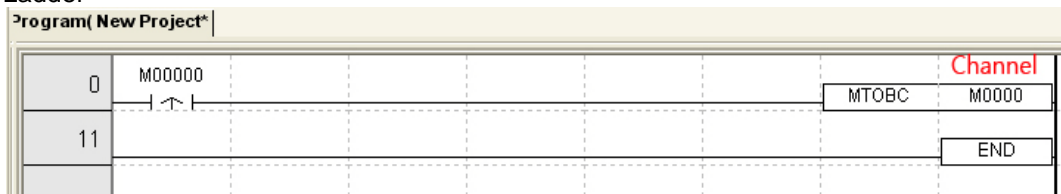

▪ Mnemonic

Step	Instruction	OP1	OP2	OP3	OP4	OP5	OP6	OP7	OP8
0	LOADP	M00000							
2	MTOBC	M0000							
11	END								

(4) H/W origin point decision

① H/W origin point decision

If setting 'H/W' of origin back kind in 'Common Configuration', origin point is decided by current position and home search direction.

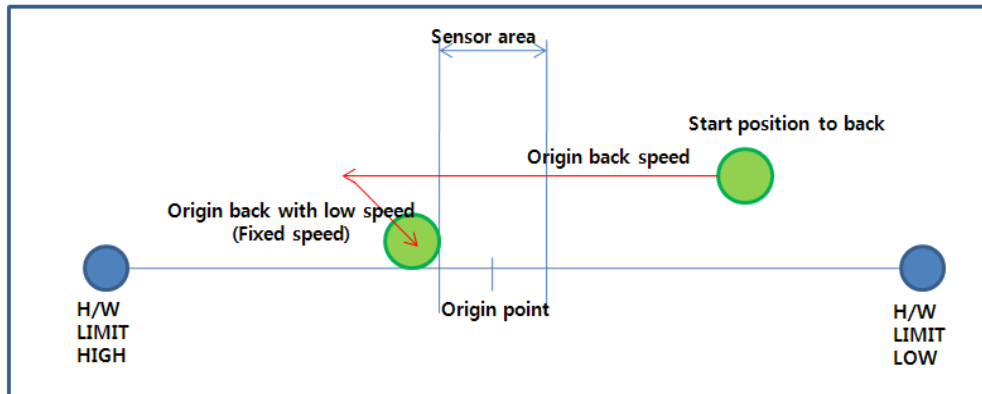

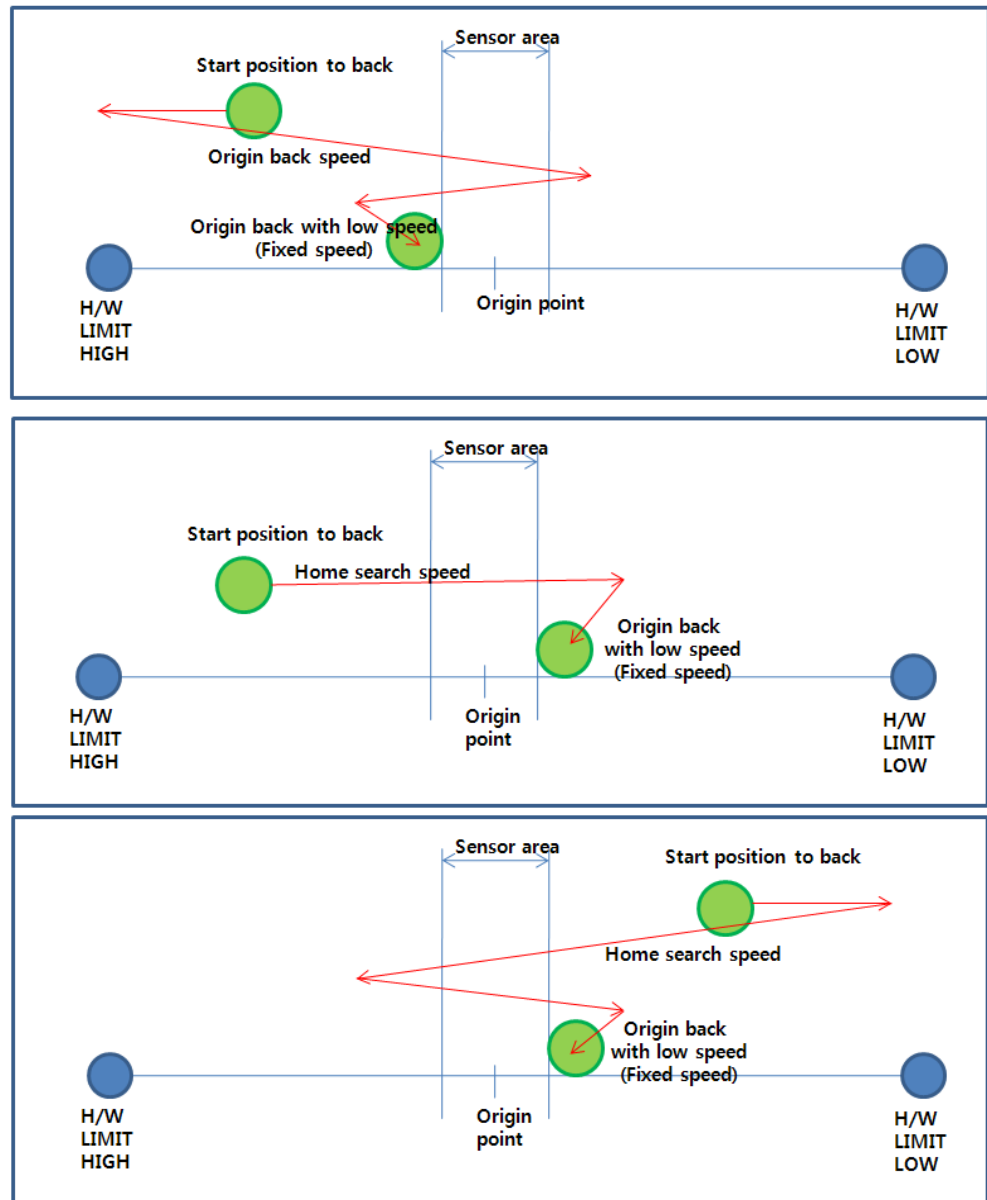

- ② S/W origin point decision
To use S/W origin point decision, use MTFOS(forced home setting) instruction to set origin point by force.

(5) Origin back

There are two types of origin back kind; H/W or S/W. H/W origin back type is searching by home search direction as same as that of the setting origin point. S/W origin back type is returning to the saved origin point with home search speed.

9.4.3.5.12.MTOVV: speed override Instruction

This instruction changes the set speed during speed driving.

(1) Instruction

MTOVV	S0	S1
--------------	-----------	-----------

(2) Operand

Operand	Type	Description	Available range
S0	WORD	CH(axis) to execute instruction	CH1 or CH2
S1	DWORD	To be changed drive speed value	1 to100,000 pps

Oper and	Device														
	X	Y	M	S	D	T	C	Z	F	V	L	R	UW	UB	Integer
S0	<input type="radio"/>	-	<input type="radio"/>	-	<input type="radio"/>	-	-	<input type="radio"/>	-	-	-	-	<input type="radio"/>	-	<input type="radio"/>
S1	<input type="radio"/>	-	<input type="radio"/>	-	<input type="radio"/>	-	-	<input type="radio"/>	-	-	-	-	<input type="radio"/>	-	<input type="radio"/>



Caution

- Be sure that if set drive speed is over than max. speed (100,000pps), it may cause malfunction.
- If set drive speed is lower than start speed, this set drive speed drives constant without acceleration/deceleration drive.
- Be sure that rapid speed change may cause motor step out.

(3) Ladder and mnemonic

- Ladder

- Mnemonic



Note

- Please use the device that matches the size of each operand.
- This instruction is only available when speed driving.
- Be sure that this instruction is not able to use in stop status.
- This instruction is available only for constant speed area. If you using this instruction to acceleration, deceleration, or dwell areas, it is not executed, and error occurs. Current action driving is continued.

(4) Function

- Executes speed override instruction at rising edge of input condition.
- Changes drive speed from current drive speed to set drive speed.

(5) Example of usage

“Changes current driving speed 10000 to 50000.”

1) ‘MOTION’ tab

MTOVV(speed override) instruction is available only when speed drive. In this example, executes speed override drive during speed direct drive. Therefore, you should set the items for speed direct drive.

Designate ‘Common Configuration’ at [Workspace]-[Parameter]-[MOTION] in SmartStudio as below figure.

Item	Ch1 Axis	Ch2 Axis
Enable Ch	TRUE	FALSE
S/W Upper Limit	2147483647	2147483647
S/W Lower Limit	-2147483647	-2147483647
Start Speed(pps)	1000	0
Orgin Point	U	0
Home Search Direction	Forward	Forward
Acceleration Time1(ms)	1000	0
Acceleration Time2(ms)	0	0
Acceleration Time3(ms)	0	0
Acceleration Time4(ms)	0	0
Acceleration Time5(ms)	0	0
Deceleration Time1(ms)	1000	0
Deceleration Time2(ms)	0	0
Deceleration Time3(ms)	0	0
Deceleration Time4(ms)	0	0
Deceleration Time5(ms)	0	0
Jog Speed(pps)	0	0
Jog Acceleration Time(ms)	0	0
Jog Deceleration Time(ms)	0	0
Acceleration Time to Orgin(ms)	1000	0
Deceleration Time to Orgin(ms)	1000	0
Home Search Speed(pps)	5000	0
Enable S/W Limit	TRUE	FALSE
Enable H/W Limit	TRUE	FALSE
Origin Back Kind	H/W	H/W

Ⓐ: drive data, Ⓑ: origin back data

2) PLC program

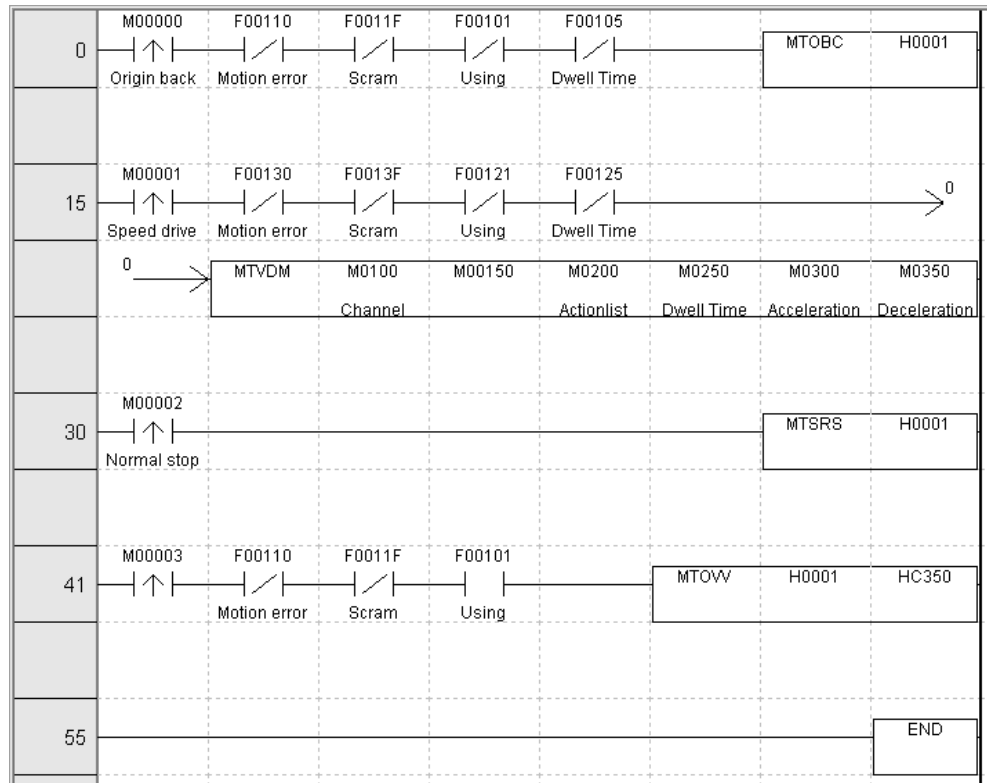

3) Drive description

This example is programmed to speed direct drive by user's input after origin back. The device is as following.

Device	Value	Description
M100	1	Using CH
M150	1	Drive direction(0: backward 1: forward)
M200	10000	Drive speed
M250	1000	Dwell time
M300	1	Acceleration time
M350	1	Deceleration time



Note

- Acceleration/Deceleration time is one of Acceleration/Deceleration time 1 to 5 of 'Common Configuration' at [Workspace]-[Parameter]-[MOTION] in SmartStudio. The other time setting is not supported.
- Basic drive data (start speed, acceleration time, deceleration time, etc) is the set value of 'Common Configuration' at [Workspace]-[Parameter]-[MOTION] in SmartStudio.

- 1st When rising edge occurs at M0 device, executes MTOBC(origin back) instruction. MTOBC(origin back) instruction searches origin point by origin back kind of 'Common Configuration' (This example is set as H/W.)
- 2nd When rising edge occurs at M1 device, executes MTVDM (speed direct drive) instruction.
- 3rd When executing MTVDM(speed direct drive) instruction, speed drives with set drive speed.
- 4th During operating MTVDM(speed direct drive) action, if rising edge occurs at M3 device, it executes MTOVV(speed override) instruction and changes drive speed to 50000.
- 5th MTOVV(speed override) instruction is speed drive. It drives continuously until MTSRS(normal stop) instruction occurs. MTOVV(speed override) instruction is able to stop by MTSRS(normal stop), or MTEMS(emergency stop) instructions.

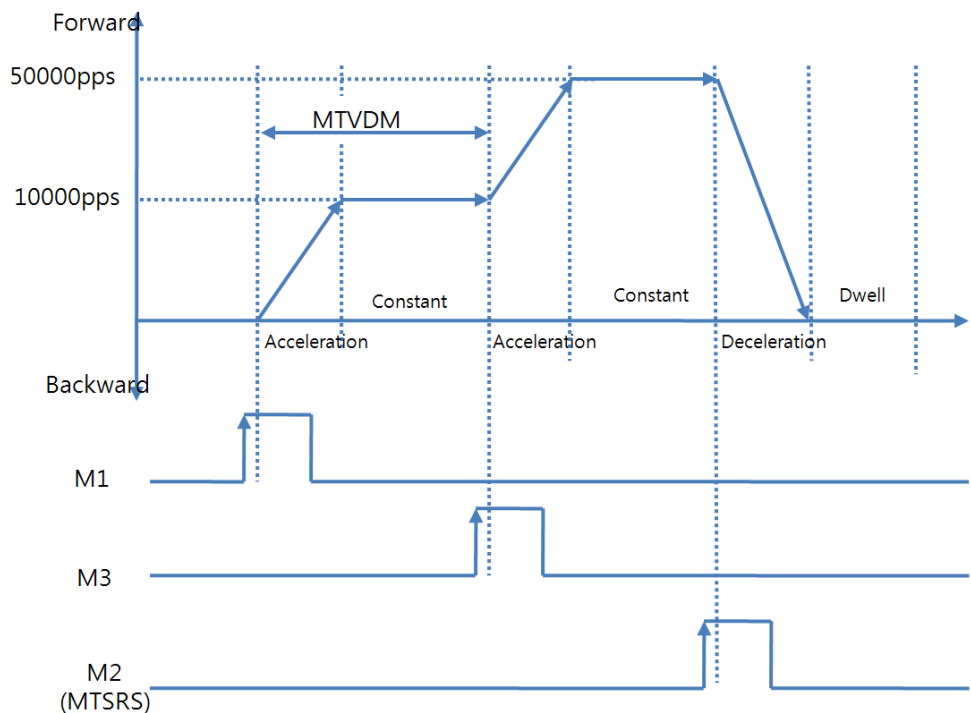

Note

Changed speed is not over maximum speed (100,000pps).

9.4.3.5.13.MTOVP: position override instruction

This instruction changes the set position as destination position.

(1) Instruction

MTOVP	S0	S1
--------------	-----------	-----------

(2) Operand

Operand	Type	Description	Available range
S0	WORD	CH(axis) to execute instruction	CH1 or CH2
S1	DWORD	To be changed position value	-2,147,483,648 to 2,147,483,647

Oper and	Device														
	X	Y	M	S	D	T	C	Z	F	V	L	R	UW	UB	Integer
S0	<input type="radio"/>	-	<input type="radio"/>	-	<input type="radio"/>	-	-	<input type="radio"/>	-	-	-	-	<input type="radio"/>	-	<input type="radio"/>
S1	<input type="radio"/>	-	<input type="radio"/>	-	<input type="radio"/>	-	-	<input type="radio"/>	-	-	-	-	<input type="radio"/>	-	<input type="radio"/>

**Note**

In case of SW limit using, changing position should not be over SW limit value.

(3) Ladder and mnemonic

▪ Ladder

Program (New Project*)		Channel		position	
0	M00000	MTOVP	M0100	M0150	Changed
11					END

▪ Mnemonic

Step	Instruction	OP1	OP2	OP3	OP4	OP5	OP6	OP7	OP8	0
0	LOADP	M00000								
2	MTOVP	M0100	M0150							
11	END									

**Note**

- Please use the device that matches the size of each operand.
- This instruction is only available when position driving.
- Be sure that this instruction is not able to use in stop status.
- This instruction is available only for constant speed area. If you using this instruction to acceleration, deceleration, or dwell areas, it is not executed, and error occurs. Current action driving is continued.

(4) Function

- Executes position override instruction at rising edge of input condition.
- Changes destination position from origin destination position to the set position during position driving.

- If set position is lower than current position, it stops at the current position.
- If set position is upper than current position, it stops at the set position.

(5) Example of usage

“Changes destination position 30000 to 50000 during position drive.”

1) 'MOTION' tab

MTOVP(position override) instruction is available only when position drive.. In this example, executes position override during position direct drive. Therefore, you should set the item for position direct drive.

Designate 'Common Configuration' at [Workspace]-[Parameter]-[MOTION] in SmartStudio as below figure.

Common Configuration		
<input type="checkbox"/> Using Internal Device	Device	
Item	Ch1 Axis	Ch2 Axis
Ⓐ Enable Ch	TRUE	FALSE
S/W Upper Limit	2147483647	2147483647
S/W Lower Limit	-2147483647	-2147483647
Ⓐ Start Speed(pps)	1000	0
Origin Point	0	0
Ⓑ Home Search Direction	Forward	Forward
Ⓐ Acceleration Time1(ms)	1000	0
Acceleration Time2(ms)	0	0
Acceleration Time3(ms)	0	0
Acceleration Time4(ms)	0	0
Acceleration Time5(ms)	0	0
Ⓐ Deceleration Time1(ms)	1000	0
Deceleration Time2(ms)	0	0
Deceleration Time3(ms)	0	0
Deceleration Time4(ms)	0	0
Deceleration Time5(ms)	0	0
Jog Speed(pps)	0	0
Jog Acceleration Time(ms)	0	0
Jog Deceleration Time(ms)	0	0
Acceleration Time to Origin(ms)	1000	0
Ⓑ Deceleration Time to Origin(ms)	1000	0
Home Search Speed(pps)	5000	0
Enable S/W Limit	TRUE	FALSE
Enable H/W Limit	TRUE	FALSE
Ⓑ Origin Back Kind	H/W	H/W

Ⓐ: drive data, Ⓑ: origin back data

2) PLC program

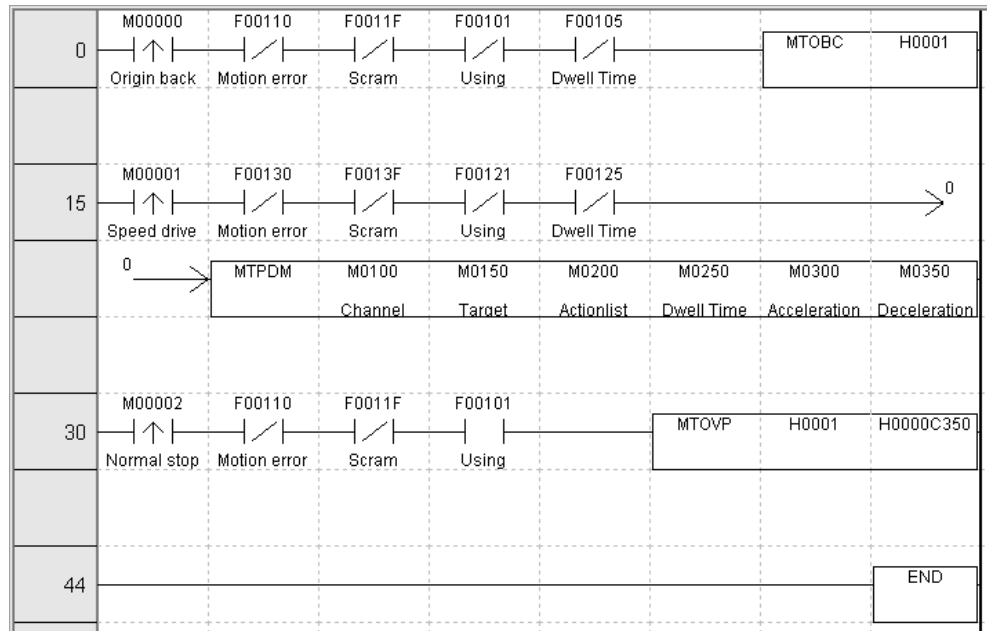

3) Drive description

This example is programmed to position direct drive by user's input after origin back. The device is as following.

Device	Value	Description
M100	1	Using CH
M150	30000	Destination position
M200	10000	Drive speed
M250	1000	Dwell time
M300	1	Acceleration time
M350	1	Deceleration time



Note

- Acceleration/Deceleration time is one of Acceleration/Deceleration time 1 to 5 of 'Common Configuration' at [Workspace]-[Parameter]-[MOTION] in SmartStudio. The other time setting is not supported.
- Basic drive data (start speed, acceleration time, deceleration time, etc) is the set value of 'Common Configuration' at [Workspace]-[Parameter]-[MOTION] in SmartStudio

- 1st When rising edge occurs at M0 device, executes MTOBC(origin back) instruction. MTOBC(origin back) instruction searches origin point by origin back kind of 'Common Configuration' (This example is set as H/W.)
- 2nd When rising edge occurs at M1 device, executes MTPDM(position direct drive) instruction.
- 3rd When executing MTPDM(position direct drive) instruction, accelerates up to the set drive speed during acceleration time and drives constant with the set drive speed.
- 4th During operating MTPDM(position direct drive) action, if rising edge occurs at M2 device, it executes MTOVP(position override) instruction and changes destination position to 50000.
- 5th Decelerates the drive for deceleration time and stops at the changed destination position.

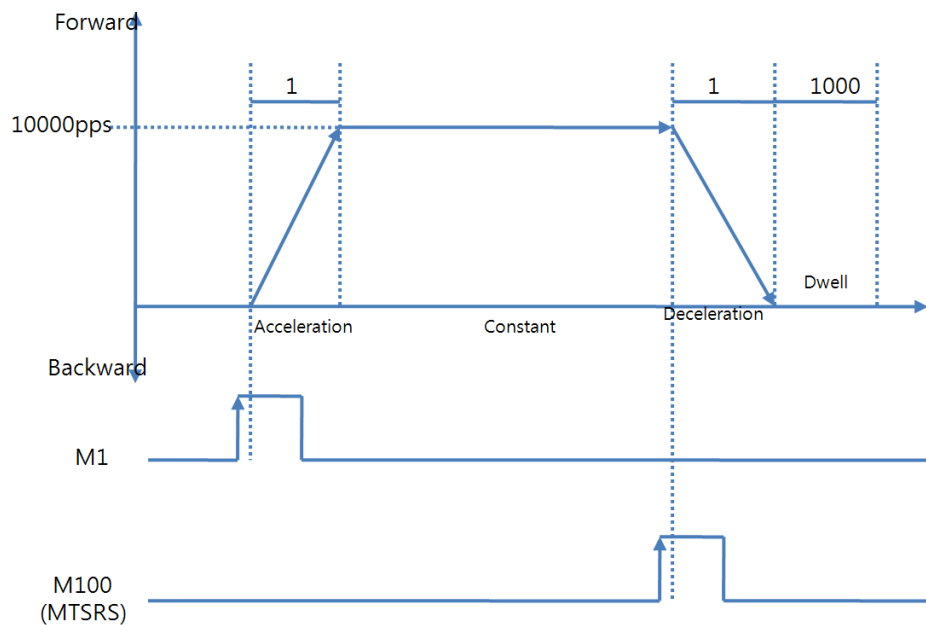

Autonics

Sensors & Controllers

www.autonics.com

Distributor

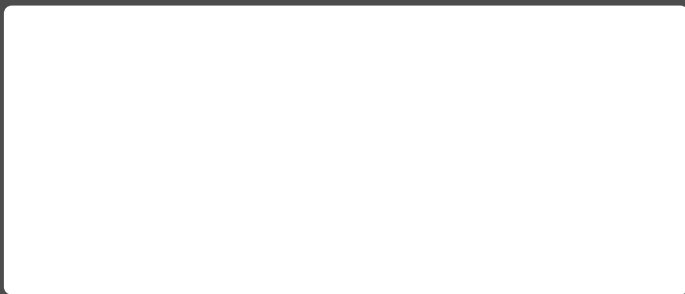

Major products

Proximity sensors • Photoelectric sensors • Area sensors • Fiber optic sensors • Door/Door Side sensors • Pressure sensors • Rotary encoders • Sensor controllers • Switching power supply • Temp. controllers • Temperature/Humidity transducers • Power controllers • Recorders • Tachometer/Pulse(Rate) meters • Panel meters • Indicators • Signal convertors • Counters • Timers • Display units • Graphic panel • Stepping Motors & Drivers & Motion controllers

■ Any proposal for a product improvement and development: Product@autonics.com

Headquarters

41-5, Yongdang-dong, Yangsan-si, Gyeongnam, 626-847, Korea

Overseas Business Dept.

Bldg. 402 3rd Fl., Bucheon Techno Park, 193, Yakdae-dong, Wonmi-gu, Bucheon-si, Gyeonggi-do, 420-734, Korea

Tel: 82-32-610-2730 / Fax: 82-32-329-0728 / E-mail: sales@autonics.com

Brazil

Autonics do Brasil Comercial Importadora Exportadora Ltda

Tel: 55-11-3055-1660 / Fax: 55-11-3055-1661 / E-mail: vendas@autonics.com.br

China

Autonics electronic(Jiaxing) Corporation

Tel: 86-573-8216-1900 / Fax: 86-573-8216-1917 / E-mail: china@autonics.com

India

Autonics Corporation - India Liaison Office

Tel: 91-22-2781-4305 / Fax: 91-22-2781-0538 / E-mail: india@autonics.com

Indonesia

PT. Autonics Indonesia

Tel: 62-21-6586-6740 / Fax: 62-21-6586-6741 / E-mail: autonics@cbrn.net.id

Japan

Autonics Japan Corporation

Tel: 81-3-5730-0568 / Fax: 81-3-5730-0569 / E-mail: ja@autonicsjp.co.jp

Malaysia

Mal-Autonics Sensor Sdn. Bhd.

Tel: 60-3-7805-7190(Hunting) / Fax: 60-3-7805-7193 / E-mail: malaysia@autonics.com

Mexico

Autonics Mexico Sales Office

Tel: 52-55-5207-0019 / Fax: 52-55-5207-0099 / E-mail: ventas@autonics.com

Russia

Autonics Corp. Russia Representative Office

Tel/Fax: 7-495-745-2343 E-mail: russia@autonics.com

Turkey

Autonics Otomasyon Ticaret Ltd. Sti.

Tel: 90-212-222-0117 (PBX) / Fax: 90-212-222-0108 / E-mail: info@autonics.com.tr

USA

Autonics USA, Inc.

Tel: 1-847-680-8160 / Fax: 1-847-680-8155 / E-mail: sales@autonicsusa.net

Vietnam

Autonics Vietnam Representative Office

Tel: 84-8-3925-6563 / Fax: 84-8-3925-6564 / E-mail: vietnam@autonics.com